

ABR series

Overview



- Special design for continuous(S1) or cyclic(S5) duty operation
- Stainless steel housing, black anodized aluminum right angle housing and motor adapter flange
- Stainless steel output shaft with or without key
- Helical gear technology
- Nominal torques:
 - T_{2N} : 14 Nm – 2000 Nm
- Ratios
 - 1-stage : 3 / 4 / 5 / 6 / 7 / 8 / 9 / 10 / 14 / 20
 - 2-stage : 15 / 20 / 25 / 30 / 35 / 40 / 45 / 50 / 60 / 70 / 80 / 90 / 100 / 120 / 140 / 160 / 180 / 200
 - * Only ABR042 2-stage offers 15 / 20 ratio.
- Low Backlash
 - 1-stage : ≤ 2 arcmin / ≤ 4 arcmin / ≤ 6 arcmin
 - 2-stage : ≤ 4 arcmin / ≤ 7 arcmin / ≤ 9 arcmin
- High efficiency
 - 1-stage : $\geq 97\%$
 - 2-stage : $\geq 94\%$
- Easy mount
- Low noise
- Compact structure
- Sizes available: ABR042 / ABR060 / ABR090 / ABR115 / ABR142 / ABR180 / ABR220

Specifications

Model No.	Stage	Ratio ¹	ABR042	ABR060	ABR090	ABR115	ABR142	ABR180	ABR220	
		3	9	36	90	195	342	588	1,140	
		4	12	48	120	260	520	1,040	1,680	
		5	15	60	150	325	650	1,200	2,000	
		6	18	55	150	310	600	1,100	1,900	
	1	7	19	50	140	300	550	1,100	1,800	
		8	17	45	120	260	500	1,000	1,600	
		9	14	40	100	230	450	900	1,500	
		10	14	40	100	230	450	900	1,500	
		14	-	42	140	300	550	1,100	1,800	
		20	-	40	100	230	450	900	1,500	
										
		15	14	-	-	-	-	-	-	
		20	14	-	-	-	-	-	-	
		25	15	60	150	325	650	1,200	2,000	
Nominal Output Torque T _{2N}	Nm	30	20	55	150	310	600	1,100	1,900	
		35	19	50	140	300	550	1,100	1,800	
		40	17	45	120	260	500	1,000	1,600	
		45	14	40	100	230	450	900	1,500	
		50	14	60	100	230	650	1,200	2,000	
	2	60	20	55	150	310	600	1,100	1,900	
		70	19	50	140	300	550	1,100	1,800	
		80	17	45	120	260	500	1,000	1,600	
		90	14	40	100	230	450	900	1,500	
		100	14	40	100	230	450	900	1,500	
		120	-	-	150	310	600	1,100	1,900	
		140	-	-	140	300	550	1,100	1,800	
		160	-	-	120	260	550	1,000	1,600	
		180	-	-	100	230	450	900	1,500	
		200	-	-	100	230	450	900	1,500	
Emergency Stop Torque T _{2NOT-3}	Nm	1,2	3~200	3 times of nominal output torque T _{2N}						
Nominal Input speed N _{1N}	rpm	1,2	3~200	5,000	5,000	4,000	4,000	3,000	3,000	2,000
Max. Input speed N _{1B}	rpm	1,2	3~200	10,000	10,000	8,000	8,000	6,000	6,000	4,000
Micro Backlash P0	arcmin	1	3~20	-	-	≤ 2	≤ 2	≤ 2	≤ 2	≤ 2
		2	25~200	-	-	≤ 4	≤ 4	≤ 4	≤ 4	≤ 4
Reduced Backlash P1	arcmin	1	3~20	≤ 4	≤ 4	≤ 4	≤ 4	≤ 4	≤ 4	≤ 4
		2	25~200	≤ 7	≤ 7	≤ 7	≤ 7	≤ 7	≤ 7	≤ 7
Standard Backlash P2	arcmin	1	3~20	≤ 6	≤ 6	≤ 6	≤ 6	≤ 6	≤ 6	≤ 6
		2	25~200	≤ 9	≤ 9	≤ 9	≤ 9	≤ 9	≤ 9	≤ 9
Torsional Rigidity	Nm/arcmin	1,2	3~200	3	7	14	25	50	145	225
Max. Radial load F _{2rB2}	N	1,2	3~200	780	1,530	3,250	6,700	9,400	14,500	50,000
Max. Axial load	F _{2a1B2}	N	1,2	3~200	350	630	1,300	3,000	4,000	6,200
	F _{2a2B2}	N	1,2	3~200	390	765	1,625	3,350	4,700	7,250
Service Life	hr	1,2	3~200	20,000 *						
Efficiency	%	1	3~20	≥ 95 %						
		2	25~200	≥ 92 %						
Weight	kg	1	3~20	0.9	2.1	6.4	13	24.5	51	83
		2	25~200	1.2	1.5	7.8	14.2	27.5	54	95
Operating Temperature	°C	1,2	3~200	-10°C~+90°C						
Lubrication		1,2	3~200	synthetic gear grease (NYOGEL 792D)						
Degree of Gearbox Protection		1,2	3~200	IP65						
Mounting position		1,2	3~200	all direction						

Noise Level
($n_1=3000$ rpm, No Load)

dB(A) 1,2 3-200 ≤ 61 ≤ 63 ≤ 65 ≤ 68 ≤ 70 ≤ 72 ≤ 74

1. Ratio ($i=N$ in / N out)
 2. Applied to the output shaft center @ 100 rpm
 3. Maximum acceleration torque $T_{2B} = 60\%$ van T_{2NOT}
- * S1 service life 10.000 uur.

Inertia

Model No.	Stage	Ratio ¹	ABR042	ABR060	ABR090	ABR115	ABR142	ABR180	ABR220
Mass Moments of inertia J _i	1	3~10	0.09	0.35	2.25	6.84	23.4	68.9	135.4
		14	-	0.07	1.87	6.25	21.8	65.6	119.8
		20	-	0.07	1.87	6.25	21.8	65.6	119.8
	2	15	0.09	-	-	-	-	-	-
		20	0.09	-	-	-	-	-	-
		25~100	0.09	0.09	0.35	2.25	6.84	23.4	68.9
		120~200	-	-	0.31	1.87	6.25	21.8	65.6

kg*cm²

Sizes

ABR series 1-stage, ratio i= 3~20

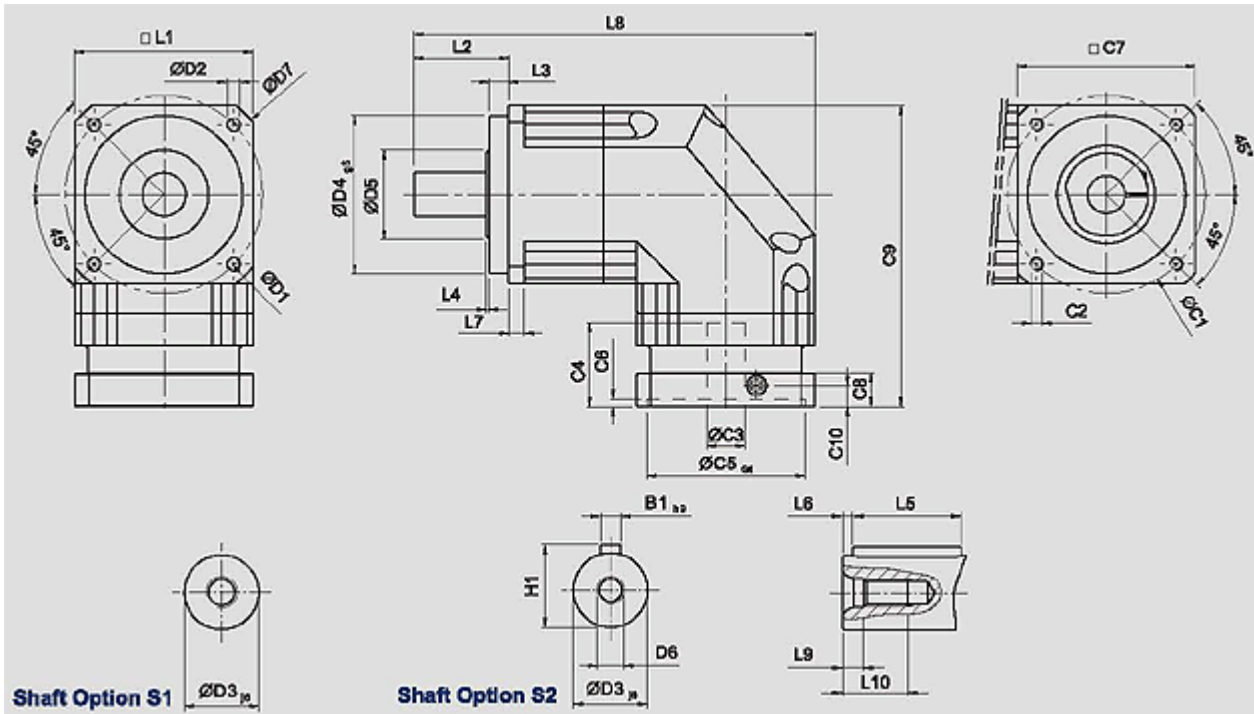

	ABR042	ABR060	ABR090	ABR115	ABR142	ABR180	ABR220
D1	50	70	100	130	165	215	250
D2	3.4	5.5	6.6	9	11	13	17
D3 j6	13	16	22	32	40	55	75
D4 g6	35	50	80	110	130	160	180
D5	22	45	65	95	75	95	115
D6	M4 X 0.7P	M5 X 0.8P	M8 X 1.25P	M12 X 1.75P	M16 X 2P	M20 X 2.5P	M20 X 2.5P
D7	56	80	116	152	185	240	292
L1	42	60	90	115	142	180	220
L2	26	37	48	65	97	105	138
L3	5.5	7	10	12	15	20	30
L4	1	1.5	1.5	2	3	3	3
L5	16	25	32	40	63	70	90
L6	2	2	3	5	5	6	7
L7	4	6	8	10	12	15	20
L8	111.5	145	203	259	333	394	484
L9	4.5	4.8	7.2	10	12	15	15
L10	10	12.5	19	28	36	42	42
C1 ³	46	70	100	130	165	215	235
C2 ³	M4 X 0.7P	M5 X 0.8P	M6 X 1P	M8 X 1.25P	M10 X 1.5P	M12 X 1.75P	M12 X 1.75P
C3 ³	≤11	≤14 / ≤16	≤19 / ≤24	≤32	≤38	≤48	≤55
C4 ³	25	30	40	50	60	85	116
C5 ³ G6	30	50	80	110	130	180	200
C6 ³	3.5	8	4	5	6	6	6
C7 ³	42	60	90	115	142	190	220
C8 ³	29.5	19	17	19.5	22.5	29	63
C9 ³	90.5	111.5	152.5	191.5	235.5	303.5	378.5
C10 ³	8.75	13.5	10.75	13	15	20.75	53
B1 _{h9}	5	5	6	10	12	16	20
H1	15	18	24.5	35	43	59	79.5

3. C1~C10 are motor specific dimensions

* ABR060M1 ratio 5,10 offers C3 =16 option.

* ABR90M1 offers C3 =24 option.

ABR series 2-stage, ratio i- 15/20~200

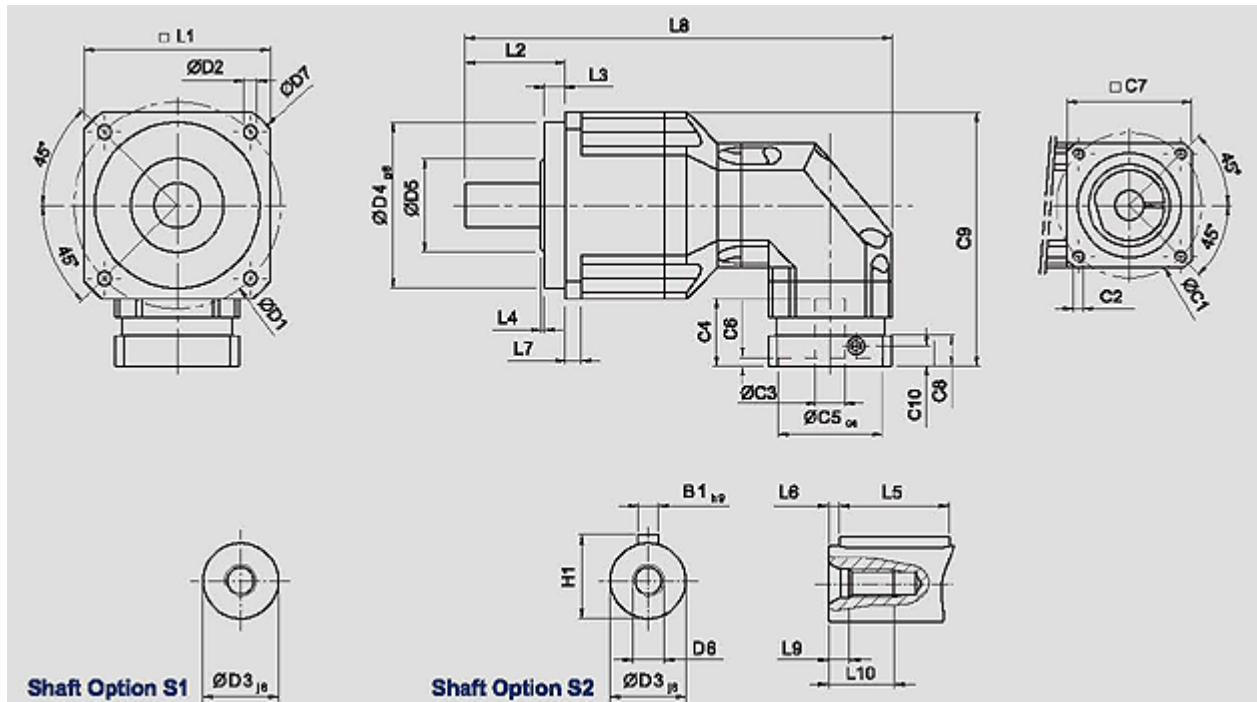

	ABR042	ABR060	ABR090	ABR115	ABR142	ABR180	ABR220
D1	50	70	100	130	165	215	250
D2	3.4	5.5	6.6	9	11	13	17
D3 j6	13	16	22	32	40	55	75
D4 g6	35	50	80	110	130	160	180
D5	22	45	65	95	75	95	115
D6	M4 X 0.7P	M5 X 0.8P	M8 X 1.25P	M12 X 1.75P	M16 X 2P	M20 X 2.5P	M20 X 2.5P
D7	56	80	116	152	185	240	292
L1	42	60	90	115	142	180	220
L2	26	37	48	65	97	105	138
L3	5.5	7	10	12	15	20	30
L4	1	1.5	1.5	2	3	3	3
L5	16	25	32	40	63	70	90
L6	2	2	3	5	5	6	7
L7	4	6	8	10	12	15	20
L8	139	163.5	206.5	285	365	431	521
L9	4.5	4.8	7.2	10	12	15	15
L10	10	12.5	19	28	36	42	42
C1 ⁴	46	46	70	100	130	165	215
C2 ⁴	M4 X 0.7P	M4 X 0.7P	M5 X 0.8P	M6 X 1P	M8 X 1.25P	M10 X 1.5P	M12 X 1.75P
C3 ⁴	≤11	≤11 / ≤12	≤14 / ≤15.875 / ≤16	≤19 / 24	≤32	≤38	≤48
C4 ⁴	25	25	34	40	50	60	82
C5 ⁴ G6	30	30	50	80	110	130	180
C6 ⁴	3.5	3.5	8	4	5	6	6
C7 ⁴	42	42	60	90	115	142	190
C8 ⁴	29.5	29.5	19	17	19.5	22.5	29

C9 ⁴	90.5	99.5	126.5	165	205	254.5	323.5
C10 ⁴	8.75	8.75	13.5	10.75	13	15	20.75
B1 h9	5	5	6	10	12	16	20
H1	15	18	24.5	35	43	59	79.5

4. C1~C10 are motor specific dimensions.

* ABR060M1 ratio 15~50 offers C3 =12 option.

* ABR090M1 ratio 15~50 offers C3 =16 option.

* ABR090M2 ratio 15~50 offers C3 =15.875 option.

* ABR115M1 bietet C3 =24 option.