

AT-FL series

Overview

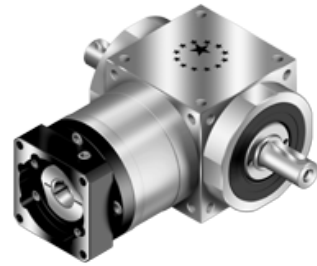

- Spiral bevel gearbox with two output shaft. Input with motor adapter.
- Stainless steel housing, aluminum black anodized motor adapter plate
- Stainless steel output shaft with or without key
- Spiral bevel gears, planetary part with spur gears
- Nominal torques:
 - T_{2N} : 12 Nm – 3.200 Nm
- Ratios
 - 1-stage : 1 / 1,5 / 2 / 3 / 4 / 5
 - 2-stage : 7 / 10 / 15 / 20 / 25 / 35 / 50
 - 3-stage : 75 / 100 / 125 / 150 / 200 / 250 / 350 / 500
- Low backlash
 - 1-stage : ≤ 6 arcmin
 - 2-stage : ≤ 8 arcmin
 - 3-stage : ≤ 10 arcmin
- High efficiency
 - 1-stage : $\geq 98\%$
 - 2-stage : $\geq 94\%$
 - 3-stage : $\geq 94\%$
- Easy mount
- Low Noise
- Compact structure
- Sizes available: AT065FL / AT075FL / AT090FL / AT110FL / AT140FL / AT170FL / AT210FL / AT240FL / AT280FL

Specifications

Model No.	Stage Ratio ¹	AT065AT075AT090AT110AT140AT170AT210 AT240 AT280										
		FL	FL	FL	FL	FL	FL	FL	FL	FL	FL	
Nominal Output Torque T_{2N}	1	1	25	45	78	150	360	585	1,300	2,150	3,200	
		1.5	25	45	78	150	360	585	1,300	2,150	3,200	
		2	24	42	68	150	330	544	1,220	2,010	3,050	
		3	18	33	54	120	270	450	1,020	1,650	2,850	
		4	13	28	48	100	224	376	860	1,410	2,300	
		5	12	25	40	85	196	320	740	1,210	2,000	
		7	12	12	33	91	91	91	195	358	358	
		10	24	28	68	150	208	208	430	846	846	
		15	18	33	54	120	270	312	645	1,269	1,269	
		2	20	13	28	48	100	224	376	860	1,410	1,629
	25		12	25	40	85	196	320	740	1,210	2,000	
	35		12	25	40	85	196	320	740	1,210	1,790	
	50		12	25	40	85	196	320	740	1,210	1,465	
	75		-	-	-	120	210	312	585	1,269	1,269	
	100		-	-	-	100	224	376	780	1,410	1,692	
	125		-	-	-	85	196	320	740	1,210	2,000	
	3		150	-	-	-	120	135	312	390	975	975
			200	-	-	-	100	180	376	520	1,300	1,300
			250	-	-	-	85	196	320	650	1,210	1,625
		350	-	-	-	85	196	320	740	1,210	1,790	
500	-	-	-	85	196	320	740	1,210	1,465			
Max Acceleration Torque T_{2B}	Nm	1,2,3	1~500	1.5 times Nominal Output Torque T_{2N}								
Max. Acceleration Input Speed n_{1B}	rpm	1	1~5	7,500	6,500	5,500	4,500	3,500	3,000	2,200	2,000	1,700
		2	7~50	8,000	8,000	6,000	6,000	6,000	6,000	4,800	3,600	3,600
		3	75~500	-	-	-	8,000	8,000	6,000	6,000	6,000	6,000
Backlash*	arcmin	1	1~5	≤6	≤6	≤6	≤6	≤6	≤6	≤6	≤6	≤6
		2	7~50	≤8	≤8	≤8	≤8	≤8	≤8	≤8	≤8	≤8
		3	75~500	-	-	-	≤10	≤10	≤10	≤10	≤10	≤10
Max. Radial Load F_{2rB} ² Output d2	N	1,2,3	1~500	900	1,100	1,700	2,700	4,800	6,600	11,500	16,000	18,000
Max. Axial Load F_{2aB} ² Output d2	N	1,2,3	1~500	450	550	850	1,350	2,400	3,300	5,750	8,500	9,000
Service Life	hr	1	1~5	20,000*								
Efficiency	%	1	1~5	≥98 %								
		2,3	7~500	≥94 %								
Weight	kg	1	1~5	2.8	4.4	7.1	12.1	20.9	36.1	69.4	101.2	158.3
		2	7~50	3.2	4.8	8.1	14.3	24.2	38.5	74.1	112.4	171.0
		3	75~500	-	-	-	13.9	23.7	38.8	73.4	110.2	168.7
Operating Temp	°C	1,2,3	1~500	-10°C~+90°C								
Lubrication		1,2,3	1~500	Synthetic Lubrication, ISO VG 150								
Noise Level ($n_1=1500$ rpm, No Load)	dB(A)	1,2,3	1~500	≤71	≤72	≤76	≤77	≤78	≤79	≤81	≤83	≤84

1. Ratio ($i=N$ in / N out)

2. Apply to the output shaft center @ 100 rpm

* S1 service life 10,000 hrs.

* Backlash is measured at 2% Nominal Output Torque T_{2N}

Rotation Direction

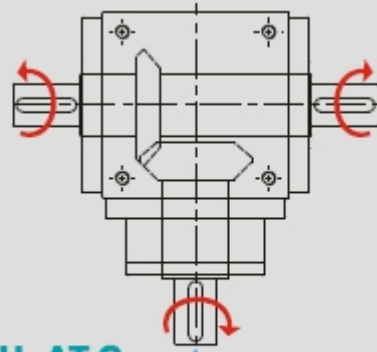

AT-L AT-H AT-C
AT-FL AT-FH AT-FC



Inertia

Model No.	Stage	Ratio ¹	AT065FL	AT075FL	AT090FL	AT110FL	AT140FL	AT170FL	AT210FL	AT240FL	AT280FL
Massa Moment of inertia J ₁	1	1	0.51	1.30	3.14	7.62	23.54	59.09	195.96	365.38	787.63
		1.5	0.46	1.15	2.80	6.65	19.34	49.38	156.02	279.62	584.28
		2	0.44	1.10	2.68	6.23	17.72	45.44	140.80	245.78	500.26
		3	0.43	1.09	2.64	6.08	17.16	44.11	135.51	233.75	471.56
		4	0.43	1.08	2.63	6.05	17.03	43.79	134.14	230.77	464.76
		5	0.43	1.08	2.63	6.04	16.99	43.69	133.71	229.71	462.08
	2	7	0.15	0.15	0.50	2.79	2.79	2.79	9.91	29.26	29.26
		10	0.15	0.15	0.50	2.80	2.80	2.80	9.96	29.43	29.43
		15	0.15	0.15	0.50	2.80	2.80	2.80	9.96	29.43	29.43
		20	0.15	0.15	0.50	2.80	2.80	2.80	9.96	29.43	29.43
		25	0.15	0.15	0.50	2.80	2.80	2.80	9.96	29.43	29.43
		35	0.15	0.15	0.50	2.79	2.79	2.79	9.91	29.26	29.26
		50	0.15	0.15	0.50	2.79	2.79	2.79	9.89	29.20	29.20
		75	-	-	-	2.80	2.80	2.80	9.96	29.43	29.43
	3	100	-	-	-	2.80	2.80	2.80	9.96	29.43	29.43
		125	-	-	-	2.80	2.80	2.80	9.96	29.43	29.43
		150	-	-	-	2.79	2.79	2.79	9.89	29.20	29.20
		200	-	-	-	2.79	2.79	2.79	9.89	29.20	29.20
		250	-	-	-	2.79	2.79	2.79	9.89	29.20	29.20
		350	-	-	-	2.79	2.79	2.79	9.89	29.20	29.20
		500	-	-	-	2.79	2.79	2.79	9.89	29.20	29.20

Sizes

AT-FL series 1-stage, ratio $i = 1 \sim 5$

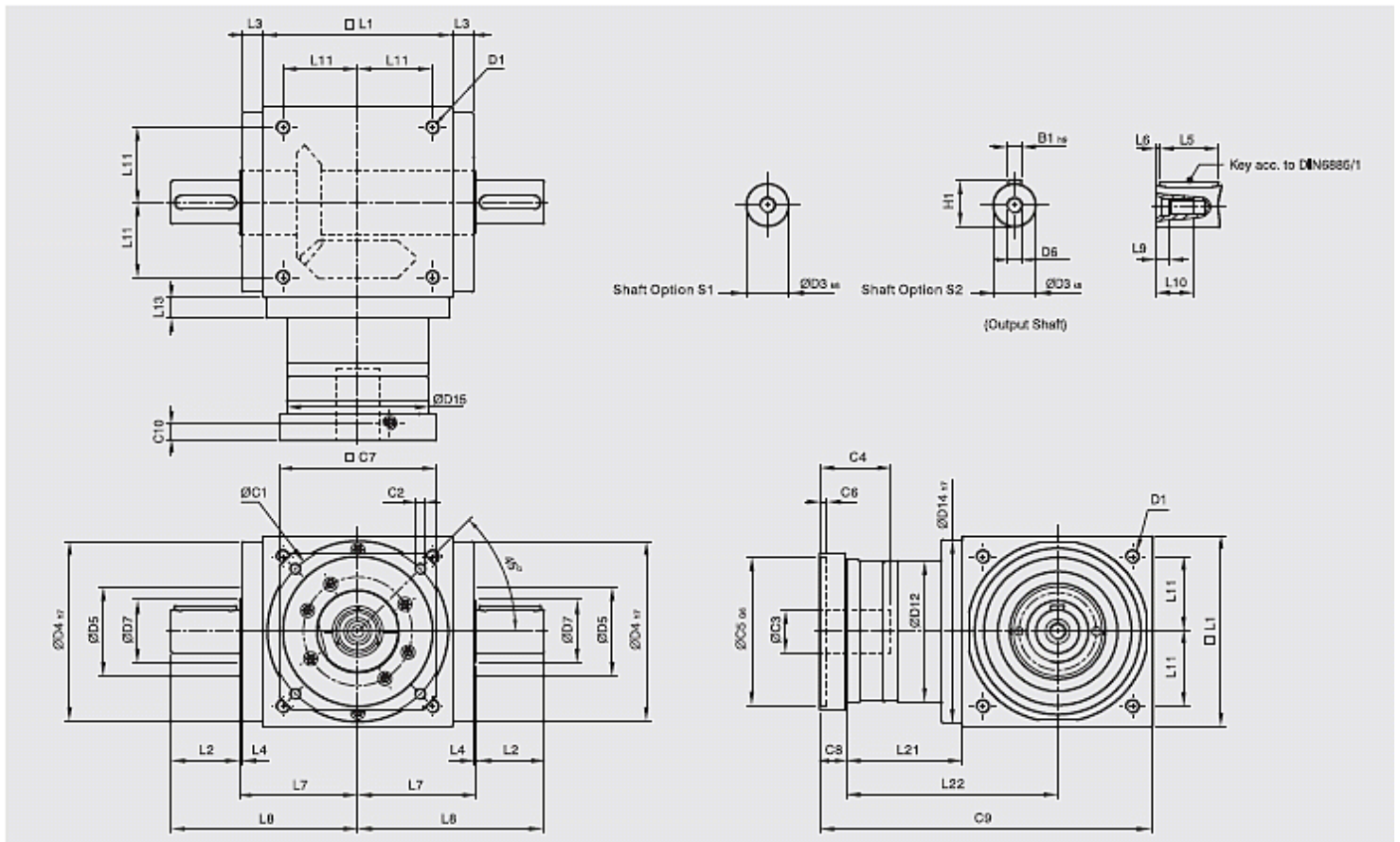

	AT065FL	AT075FL	AT090FL	AT110FL	AT140FL	AT170FL	AT210FL	AT240FL	AT280FL
D1	M4	M6	M6	M8	M10	M12	M16	M16	M16
D3 _{k6}	13	16	18	22	32	40	50	55	60
D4 _{h7}	63	73	88	108	135	165	205	235	275
D5	31	35	43	53	68	83	104	124	144
D6	M4	M5	M5	M8	M12	M16	M16	M16	M20
D7	21	22	28	33	47	55	75	85	110
D12	62	72	86	106	104	128	160	180	200
D14 _{h7}	63	73	88	108	135	165	205	235	275
D15	62.9	72.9	87	107	105	127	158	178	198
L1	65	75	90	110	140	170	210	240	280
L2	19.5	30	35	40	50	60	75	85	110
L3	13	14.5	15	15	15	15	20	25	25
L4	2	2	2	2	2	2	2	2	2
L5	16	25	28	32	45	50	70	80	100
L6	2	2.5	3.5	4	2.5	5	2.5	2.5	5
L7	47.5	54	62	72	87	102	127	147	167
L8	67	84	97	112	137	162	202	232	277
L9	4.5	4.8	4.8	7.2	10	12	12	12	15
L10	10	12.5	12.5	19	28	36	36	36	42
L11	27	30	36	44	55	67	85	95	110
L13	13	15	15	15	15	15	20	25	25
L21	49	60.5	63	69.5	85.5	95	130	144.5	135
L22	81.5	98	108	124.5	155.5	180	235	264.5	275
C1 ³	46	70	100	100	130	165	215	215	235
C2 ³	M4	M5	M6	M6	M8	M10	M12	M12	M12

C3 ³	≤11 ≤12	≤14 ≤15.875 ≤16	≤19	≤24	≤32	≤38	≤42	≤48	≤55
C4 ³	30	34	40	40	50	60	85	85	116
C5 ³ _{G6}	30	50	80	80	110	130	180	180	200
C6 ³	3.5	8	4	4	5	6	6	6	6
C7 ³	42	60	90	90	115	142	190	190	220
C8 ³	19.5	19	17	17	19.5	22.5	29	29	63
C9 ³	133.5	154.5	170	196.5	245	287.5	369	413.5	478
C10 ³	13.25	13.5	10.75	10.75	13	15	20.75	20.75	53.5
B1 _{h9}	5	5	6	6	10	12	14	16	18
H1	15	18	20.5	24.5	35	43	53.5	59	64

3. C1~C10 are motor specific dimensions (metric std shown).

AT-FL series 2-stage, ratio i = 7 ~ 50

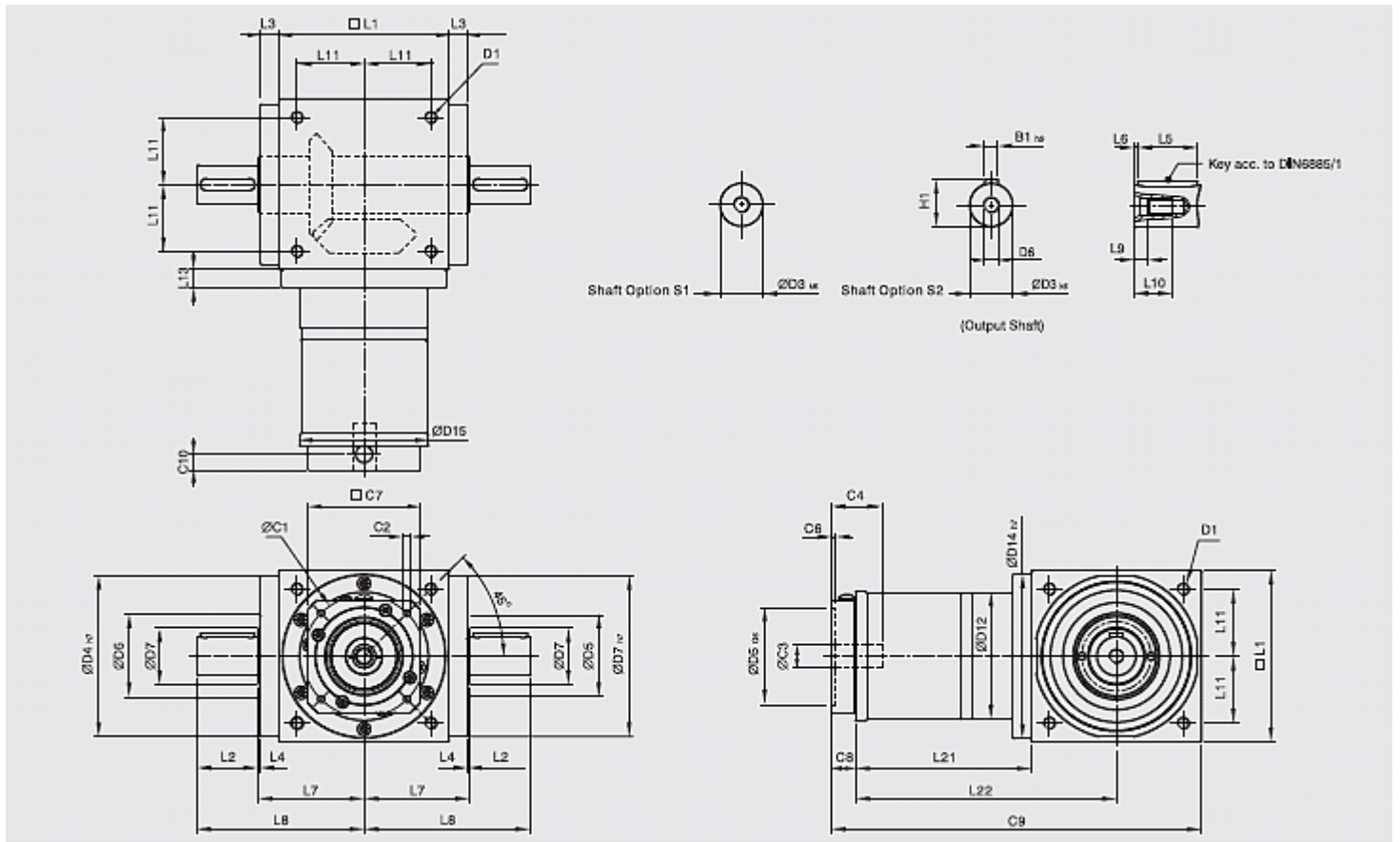

	AT065FL	AT075FL	AT090FL	AT110FL	AT140FL	AT170FL	AT210FL	AT240FL	AT280FL
D1	M4	M6	M6	M8	M10	M12	M16	M16	M16
D3 _{k6}	13	16	18	22	32	40	50	55	60
D4 _{h7}	63	73	88	108	135	165	205	235	275
D5	31	35	43	53	68	83	104	124	144
D6	M4	M5	M5	M8	M12	M16	M16	M16	M20
D7	21	22	28	33	47	55	75	85	110
D12	62	72	86	106	104	128	160	180	200
D14 _{h7}	63	73	88	108	135	165	205	235	275
D15	62.9	72.9	87	107	106	127	158	178	198
L1	65	75	90	110	140	170	210	240	280

L2	19.5	30	35	40	50	60	75	85	110
L3	13	14.5	15	15	15	15	20	25	25
L4	2	2	2	2	2	2	2	2	2
L5	16	25	28	32	45	50	70	80	100
L6	2	2.5	3.5	4	2.5	5	2.5	2.5	5
L7	47.5	54	62	72	87	102	127	147	167
L8	67	84	97	112	137	162	202	232	277
L9	4.5	4.8	4.8	7.2	10	12	12	12	15
L10	10	12.5	12.5	19	28	36	36	36	42
L11	27	30	36	44	55	67	85	95	110
L13	13	15	15	15	15	15	20	25	25
L21	75	84.5	99	122	144.5	157.5	206.5	239	248
L22	107.5	122	144	177	214.5	242.5	311.5	359	388
C1 ⁴	46	46	70	100	100	100	130	165	165
C2 ⁴	M4	M4	M5	M6	M6	M6	M8	M10	M10
C3 ⁴	≤12	≤12	≤16	≤24	≤24	≤24	≤32	≤38	≤38
C4 ⁴	30	30	34	40	40	40	50	60	60
C5 ⁴ _{G6}	30	30	50	80	80	80	110	130	130
C6 ⁴	3.5	3.5	8	4	4	4	5	6	6
C7 ⁴	42	42	60	92	92	92	115	142	142
C8 ⁴	21.5	21.5	21.5	20	20	20	24	31	31
C9 ⁴	161.5	181	210.5	252	304.5	347.5	440.5	510	559
C10 ⁴	14.5	14.5	15.5	13	13	13	16	21	21
B1 _{h9}	5	5	6	6	10	12	14	16	18
H1	15	18	20.5	24.5	35	43	53.5	59	64

4. C1~C10 are motor specific dimensions (metric std shown).

AT-FL series 3-stage, ratio $i = 75 \sim 500$

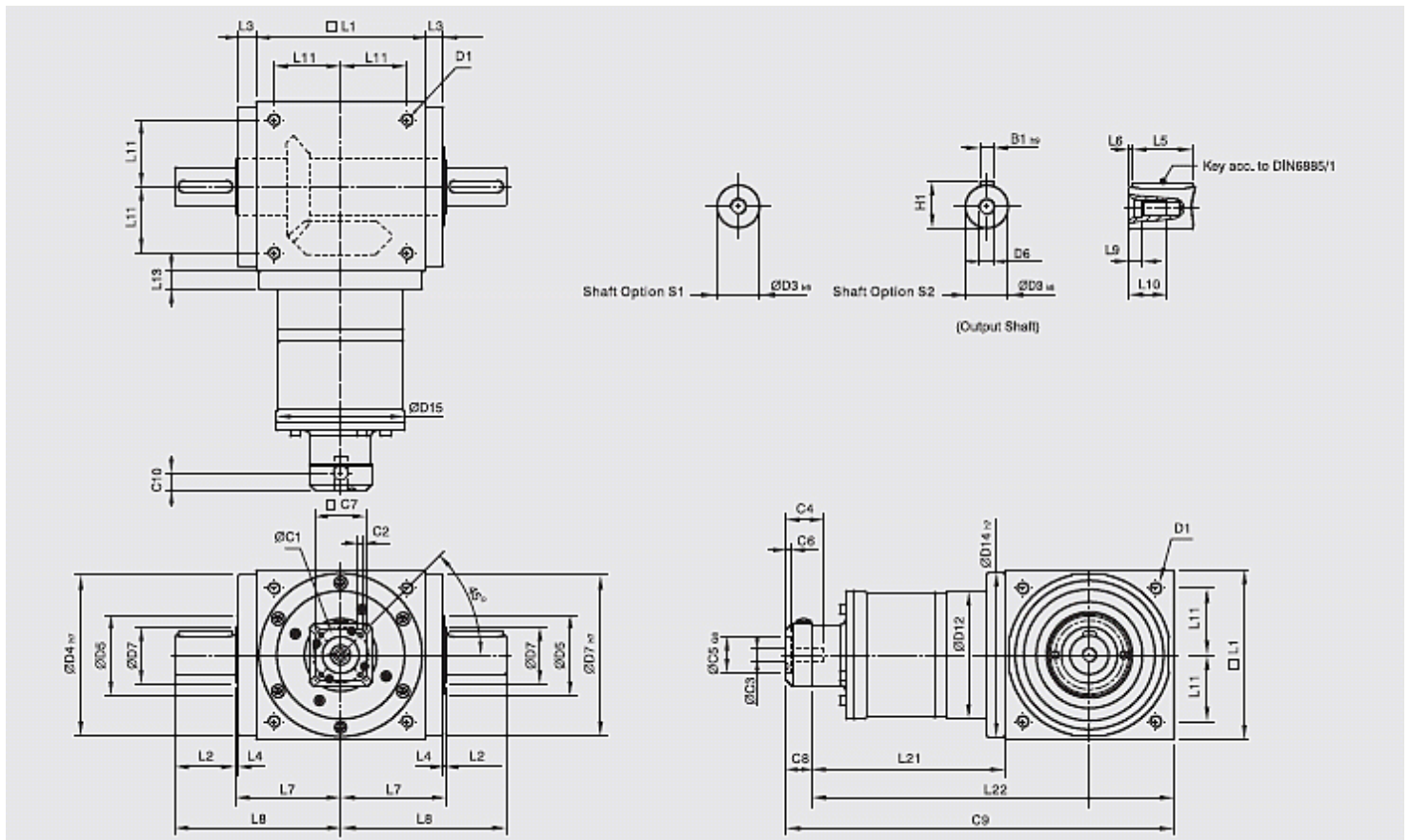

	AT110FL	AT140FL	AT170FL	AT210FL	AT240FL	AT280FL
D1	M8	M10	M12	M16	M16	M16
D3 _{k6}	22	32	40	50	55	60
D4 _{h7}	108	135	165	205	235	275
D5	53	68	83	104	124	144
D6	M8	M12	M16	M16	M16	M20
D7	33	47	55	75	85	110
D12	106	104	128	160	180	200
D14 _{h7}	108	135	165	205	235	275
D15	107	106	127	158	178	198
L1	110	140	170	210	240	280
L2	40	50	60	75	85	110
L3	15	15	15	20	25	25
L4	2	2	2	2	2	2
L5	32	45	50	70	80	100
L6	4	2.5	5	2.5	2.5	5
L7	72	87	102	127	147	167
L8	112	137	162	202	232	277
L9	7.2	10	12	12	12	15
L10	19	28	36	36	36	42
L11	44	55	67	85	95	110
L13	15	15	15	20	25	25
L21	136.5	159.5	183.5	226	269	278
L22	191.5	229.5	268.5	331	389	418
C1 ⁵	46	46	70	70	100	100
C2 ⁵	M4	M4	M5	M5	M6	M6
C3 ⁵	≤12	≤12	≤16	≤16	≤24	≤24
C4 ⁵	30	30	34	34	40	40
C5 ⁵ _{G6}	30	30	50	50	80	80
C6 ⁵	3.5	3.5	8	8	4	4
C7 ⁵	42	42	60	60	92	92
C8 ⁵	21.5	21.5	21.5	21.5	20	20
C9 ⁵	268	321	375	457.5	529	578
C10 ⁵	14.5	14.5	15.5	15.5	13	13
B2 _{h9}	6	10	12	14	16	18
H1	24.5	35	43	53.5	59	64

5. C1~C10 are motor specific dimensions (metric std shown).