

ATB-FH series

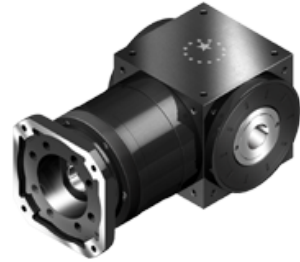

Overview

- Spiral bevel gearbox with output hollow shaft thru with keyway. Input with motor adapter
- Steel housing, black oxidized, aluminum black anodized motor adapter plate
- Steel hollow output shaft with thru keyway
- Spiral bevel gears, planetary part with spur gears
- Nominal torques:
 - T_{2N} : 12 Nm – 3.200 Nm
- Ratios
 - 1-stage : 1 / 1,5 / 2 / 3 / 4 / 5
 - 2-stage : 7 / 10 / 15 / 20 / 25 / 35 / 50
 - 3-stage : 75 / 100 / 125 / 150 / 200 / 250 / 350 / 500
- Low backlash
 - 1-stages : ≤ 6 arcmin
 - 2-stages : ≤ 8 arcmin
 - 3-stage : ≤ 10 arcmin
- High efficiency
 - 1-stage : $\geq 98\%$
 - 2-stage : $\geq 94\%$
 - 3-stage : $\geq 94\%$
- Easy mount
- Low Noise
- Compact structure
- Size available: ATB065FH / ATB075FH / ATB090FH / ATB110FH / ATB140FH / ATB170FH / ATB210FH / ATB240FH / ATB280FH

Specifications

Model No.	Stage Ratio ¹	ATB065ATB075ATB090ATB110ATB140ATB170ATB210ATB240ATB280										
		FH	FH	FH	FH	FH	FH	FH	FH	FH	FH	
Nominal Output Torque T_{2N}	1	1	25	45	78	150	360	585	1,300	2,150	3,200	
		1.5	25	45	78	150	360	585	1,300	2,150	3,200	
		2	24	42	68	150	330	544	1,220	2,010	3,050	
		3	18	33	54	120	270	450	1,020	1,650	2,850	
		4	13	28	48	100	224	376	860	1,410	2,300	
		5	12	25	40	85	196	320	740	1,210	2,000	
		7	12	12	33	91	91	91	195	358	358	
		10	24	28	68	150	208	208	430	846	846	
		15	18	33	54	120	270	312	645	1,269	1,269	
		20	13	28	48	100	224	376	860	1,410	1,629	
	2	25	12	25	40	85	196	320	740	1,210	2,000	
		35	12	25	40	85	196	320	740	1,210	1,790	
		50	12	25	40	85	196	320	740	1,210	1,465	
		75	-	-	-	120	210	312	585	1,269	1,269	
		100	-	-	-	100	224	376	780	1,410	1,692	
		125	-	-	-	85	196	320	740	1,210	2,000	
		3	150	-	-	-	120	135	312	390	975	975
			200	-	-	-	100	180	376	520	1,300	1,300
			250	-	-	-	85	196	320	650	1,210	1,625
			350	-	-	-	85	196	320	740	1,210	1,790
500	-		-	-	85	196	320	740	1,210	1,465		
Max Acceleration Torque T_{2B}	Nm	1,2,3	1~500	1.5 times Nominal Output Torque T_{2N}								
Max. Acceleration Input Speed n_{1B}	rpm	1	1~5	7,500	6,500	5,500	4,500	3,500	3,000	2,200	2,000	1,700
		2	7~50	8,000	8,000	6,000	6,000	6,000	6,000	4,800	3,600	3,600
		3	75~500	-	-	-	8,000	8,000	6,000	6,000	6,000	6,000
Backlash*	arcmin	1	1~5	≤6	≤6	≤6	≤6	≤6	≤6	≤6	≤6	≤6
		2	7~50	≤8	≤8	≤8	≤8	≤8	≤8	≤8	≤8	≤8
		3	75~500	-	-	-	≤10	≤10	≤10	≤10	≤10	≤10
Max. Radial Load F_{2rB} Output d2	N	1,2,3	1~500	900	1,100	1,700	2,700	4,800	6,600	11,500	16,000	18,000
Max. Axial Load F_{2aB} Output d2	N	1,2,3	1~500	450	550	850	1,350	2,400	3,300	5,750	8,500	9,000
Service Life	hr	1	1~5	20,000*								
Efficiency	%	1	1~5	≥98%								
		2,3	7~500	≥94%								
Weight	kg	1	1~5	2.6	4.1	6.7	11.4	18.9	32.9	63.2	92.5	146.0
		2	7~50	3.1	4.6	7.7	13.6	22.4	35.3	67.9	103.7	158.7
		3	75~500	-	-	-	13.3	21.9	35.6	67.2	101.5	156.5
Operating Temp	°C	1,2,3	1~500	-10°C~+90°C								
Lubrication		1,2,3	1~500	Synthetic lubrication, ISO VG 150								
Noise Level ($n_1=1500$ rpm, No Load)	dB(A)	1,2,3	1~500	≤71	≤72	≤76	≤77	≤78	≤79	≤81	≤83	≤84

1. Ratio ($i=N$ in / N out)

2. Apply to the output shaft center @ 100 rpm

3. Apply to the output shaft center @ 100 rpm

* S1 service life 10,000 hrs.

* Backlash is measured at 2% Nominal Output Torque T_{2N}

Rotation direction

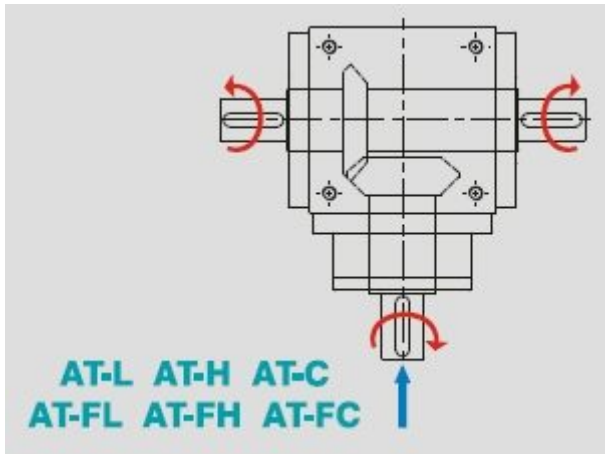

Inertia

Model No.	Stage	Ratio ¹	ATB 065FH	ATB 075FH	ATB 090FH	ATB 110FH	ATB 140FH	ATB 170FH	ATB 210FH	ATB 240FH	ATB 280FH
Mass Moment of inertia J ₁	1	1	0.51	1.30	3.14	7.62	23.54	59.09	195.96	365.38	787.63
		1.5	0.46	1.15	2.80	6.65	19.34	49.38	156.02	279.62	584.28
		2	0.44	1.10	2.68	6.23	17.72	45.44	140.80	245.78	500.26
		3	0.43	1.09	2.64	6.08	17.16	44.11	135.51	233.75	471.56
		4	0.43	1.08	2.63	6.05	17.03	43.79	134.14	230.77	464.76
		5	0.43	1.08	2.63	6.04	16.99	43.69	133.71	229.71	462.08
		7	0.15	0.15	0.50	2.79	2.79	2.79	9.91	29.26	29.26
	2	10	0.15	0.15	0.50	2.80	2.80	2.80	9.96	29.43	29.43
		15	0.15	0.15	0.50	2.80	2.80	2.80	9.96	29.43	29.43
		20	0.15	0.15	0.50	2.80	2.80	2.80	9.96	29.43	29.43
		25	0.15	0.15	0.50	2.80	2.80	2.80	9.96	29.43	29.43
		35	0.15	0.15	0.50	2.79	2.79	2.79	9.91	29.26	29.26
		50	0.15	0.15	0.50	2.79	2.79	2.79	9.89	29.20	29.20
		75	-	-	-	2.80	2.80	2.80	9.96	29.43	29.43
	3	100	-	-	-	2.80	2.80	2.80	9.96	29.43	29.43
		125	-	-	-	2.80	2.80	2.80	9.96	29.43	29.43
		150	-	-	-	2.79	2.79	2.79	9.89	29.20	29.20
		200	-	-	-	2.79	2.79	2.79	9.89	29.20	29.20
		250	-	-	-	2.79	2.79	2.79	9.89	29.20	29.20
		350	-	-	-	2.79	2.79	2.79	9.89	29.20	29.20
		500	-	-	-	2.79	2.79	2.79	9.89	29.20	29.20

Sizes

ATB-FH series 1-stage, ratio $i = 1 \sim 5$

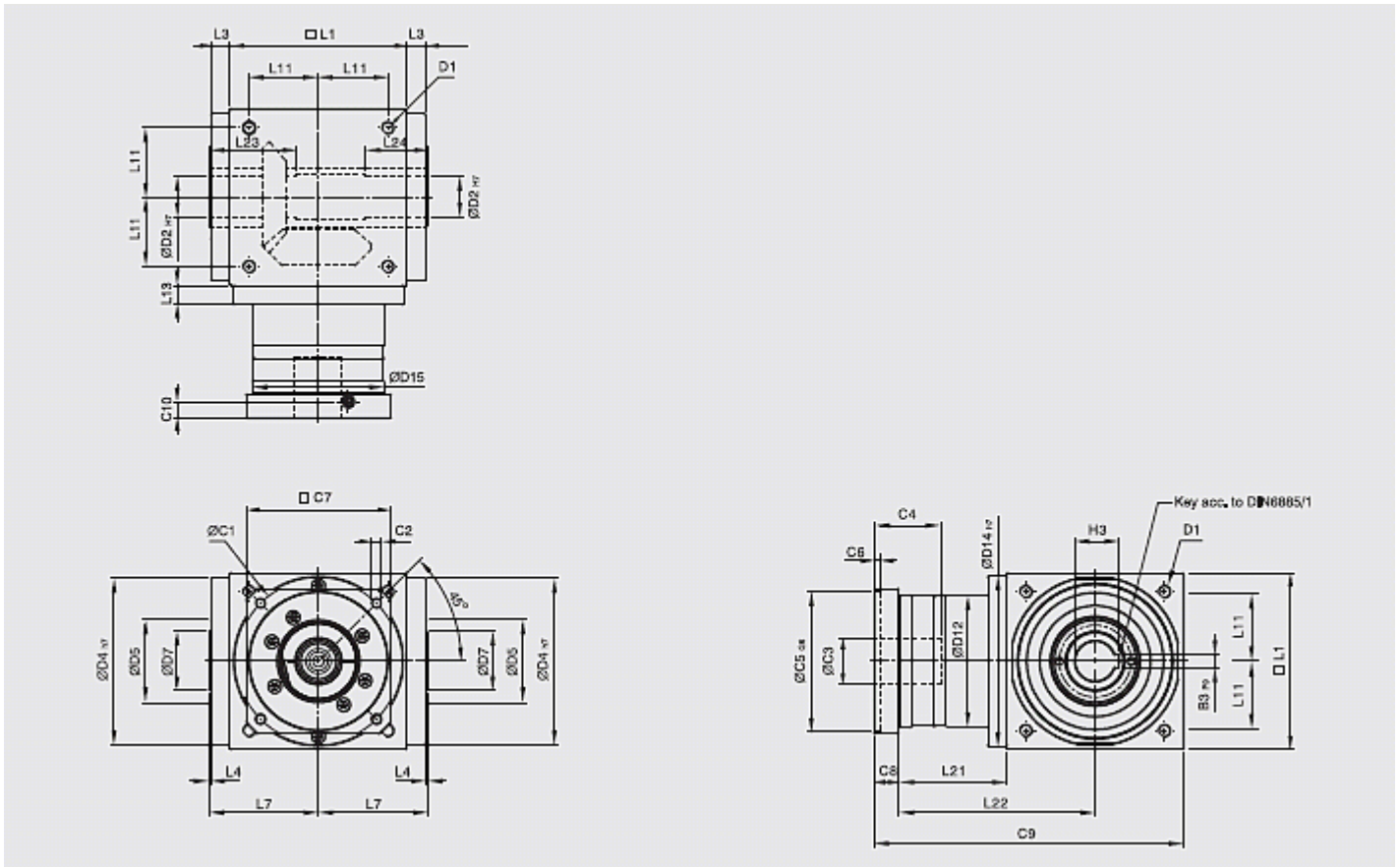

	AT0B65FH	ATB075FH	ATB090FH	ATB110FH	ATB140FH	ATB170FH	ATB210FH	ATB240FH	ATB280FH
D1	M4	M6	M6	M8	M10	M12	M16	M16	M16
D2 _{H7}	13	14	18	22	32	40	50	55	60
D4 _{H7}	63	73	88	108	135	165	205	235	275
D5	31	35	43	53	68	83	104	124	144
D7	21	22	28	33	47	55	75	85	110
D12	62	72	86	106	104	128	160	180	200
D14 _{H7}	63	73	88	108	135	165	205	235	275
D15	62.9	72.9	87	107	105	127	158	178	198
L1	65	75	90	110	140	170	210	240	280
L3	13	14.5	15	15	15	15	20	25	25
L4	2	2	2	2	2	2	2	2	2
L7	47.5	54	62	72	87	102	127	147	167
L11	27	30	36	44	55	67	85	95	110
L13	13	15	15	15	15	15	20	25	25
L21	49	60.5	63	69.5	85.5	95	130	144.5	135
L22	81.5	98	108	124.5	155.5	180	235	264.5	275
L23	40	47	55	60	70	80	95	115	130
L24	30	32	35	40	50	55	65	80	80
C1 [°]	46	70	100	100	130	165	215	215	235
C2 [°]	M4	M5	M6	M6	M8	M10	M12	M12	M12
C3 [°]	≤11 ≤12	≤14 ≤15.875 ≤16	≤19	≤24	≤32	≤38	≤42	≤48	≤55
C4 [°]	30	34	40	40	50	60	85	85	116
C5 ^{°_{G6}}	30	50	80	80	110	130	180	180	200
C6 [°]	3.5	8	4	4	5	6	6	6	6

C7 [°]	42	60	90	90	115	142	190	190	220
C8 [°]	19.5	19	17	17	19.5	22.5	29	29	63
C9 [°]	133.5	154.5	170	196.5	245	287.5	369	413.5	478
C10 [°]	13.25	13.5	10.75	10.75	13	15	20.75	20.75	53.5
B3 _{h9}	5	5	6	6	10	12	14	16	18
H3	15.3	16.3	20.8	24.8	35.5	43.3	53.8	59.3	64.4

9. C1~C10 are motor specific dimensions (metric std shown).

ATB-FH series 2-stage, ratio i = 7 ~ 50

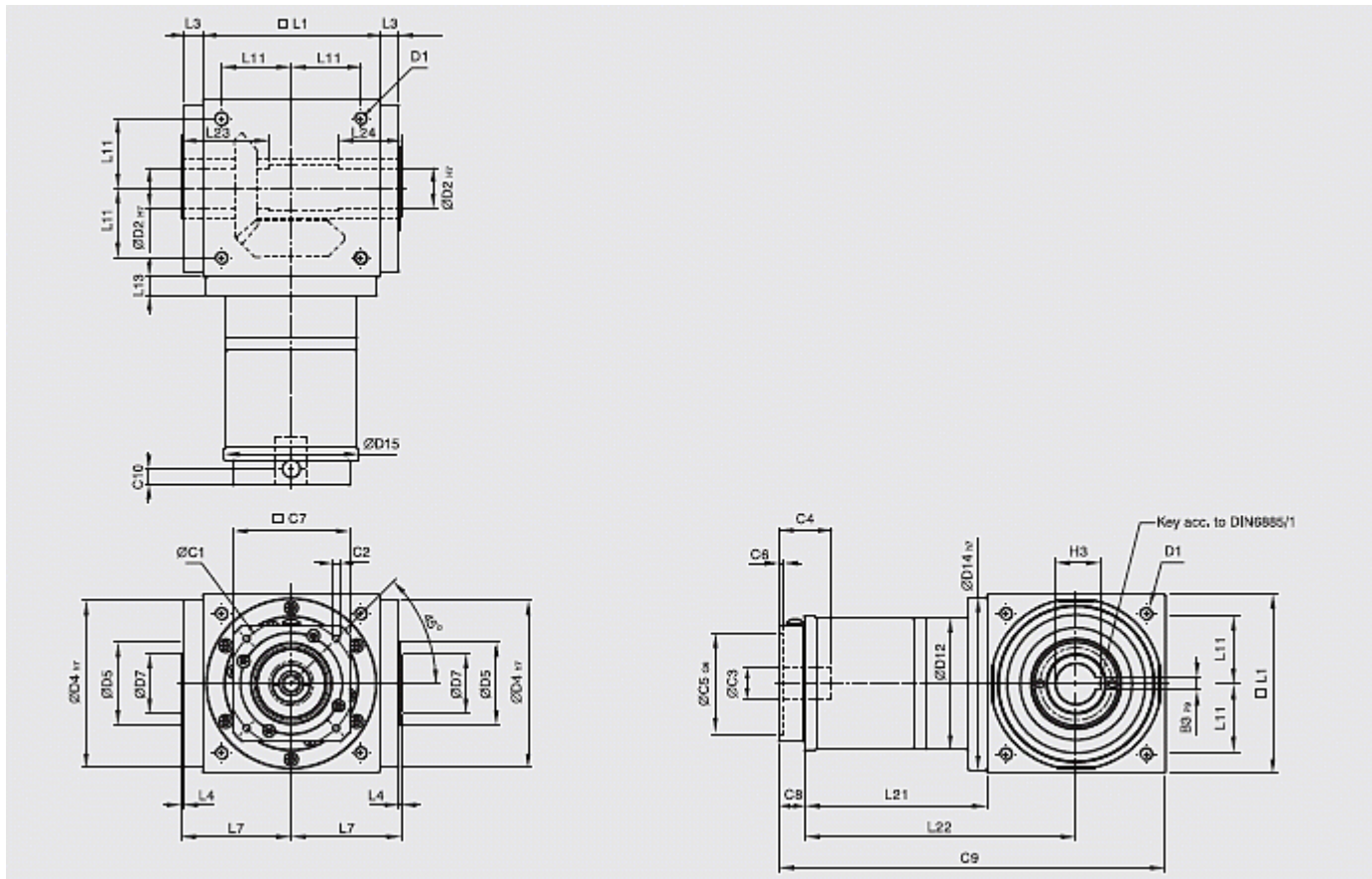

	ATB065FH	ATB075FH	ATB090FH	ATB110FH	ATB140FH	ATB170FH	ATB210FH	ATB240FH	ATB280FH
D1	M4	M6	M6	M8	M10	M12	M16	M16	M16
D2 _{h7}	13	14	18	22	32	40	50	55	60
D4 _{h7}	63	73	88	108	135	165	205	235	275
D5	31	35	43	53	68	83	104	124	144
D7	21	22	28	33	47	55	75	85	110
D12	62	72	86	106	104	128	160	180	200
D14 _{h7}	63	73	88	108	135	165	205	235	275
D15	62.9	72.9	87	107	106	127	158	178	198
L1	65	75	90	110	140	170	210	240	280
L3	13	14.5	15	15	15	15	20	25	25
L4	2	2	2	2	2	2	2	2	2
L7	47.5	54	62	72	87	102	127	147	167
L11	27	30	36	44	55	67	85	95	110
L13	13	15	15	15	15	15	20	25	25
L21	75	84.5	99	122	144.5	157.5	206.5	239	248

L22	107.5	122	144	177	214.5	242.5	311.5	359	388
L23	40	47	55	60	70	80	95	115	130
L24	30	32	35	40	50	55	65	80	80
C1 ¹⁰	46	46	70	100	100	100	130	165	165
C2 ¹⁰	M4	M4	M5	M6	M6	M6	M8	M10	M10
C3 ¹⁰	≤12	≤12	≤16	≤24	≤24	≤24	≤32	≤38	≤38
C4 ¹⁰	30	30	34	40	40	40	50	60	60
C5 ¹⁰ _{GG}	30	30	50	80	80	80	110	130	130
C6 ¹⁰	3.5	3.5	8	4	4	4	5	6	6
C7 ¹⁰	42	42	60	92	92	92	115	142	142
C8 ¹⁰	21.5	21.5	21.5	20	20	20	24	31	31
C9 ¹⁰	161.5	181	210.5	252	304.5	347.5	440.5	510	559
C10 ¹⁰	14.5	14.5	15.5	13	13	13	16	21	21
B3 _{P9}	5	5	6	6	10	12	14	16	18
H3	15.3	16.3	20.8	24.8	35.3	43.3	53.8	59.3	64.4

10. C1~C10 are motor specific dimensions (metric std shown).

ATB-FH serie s3-stage, ratio i = 75 ~ 500

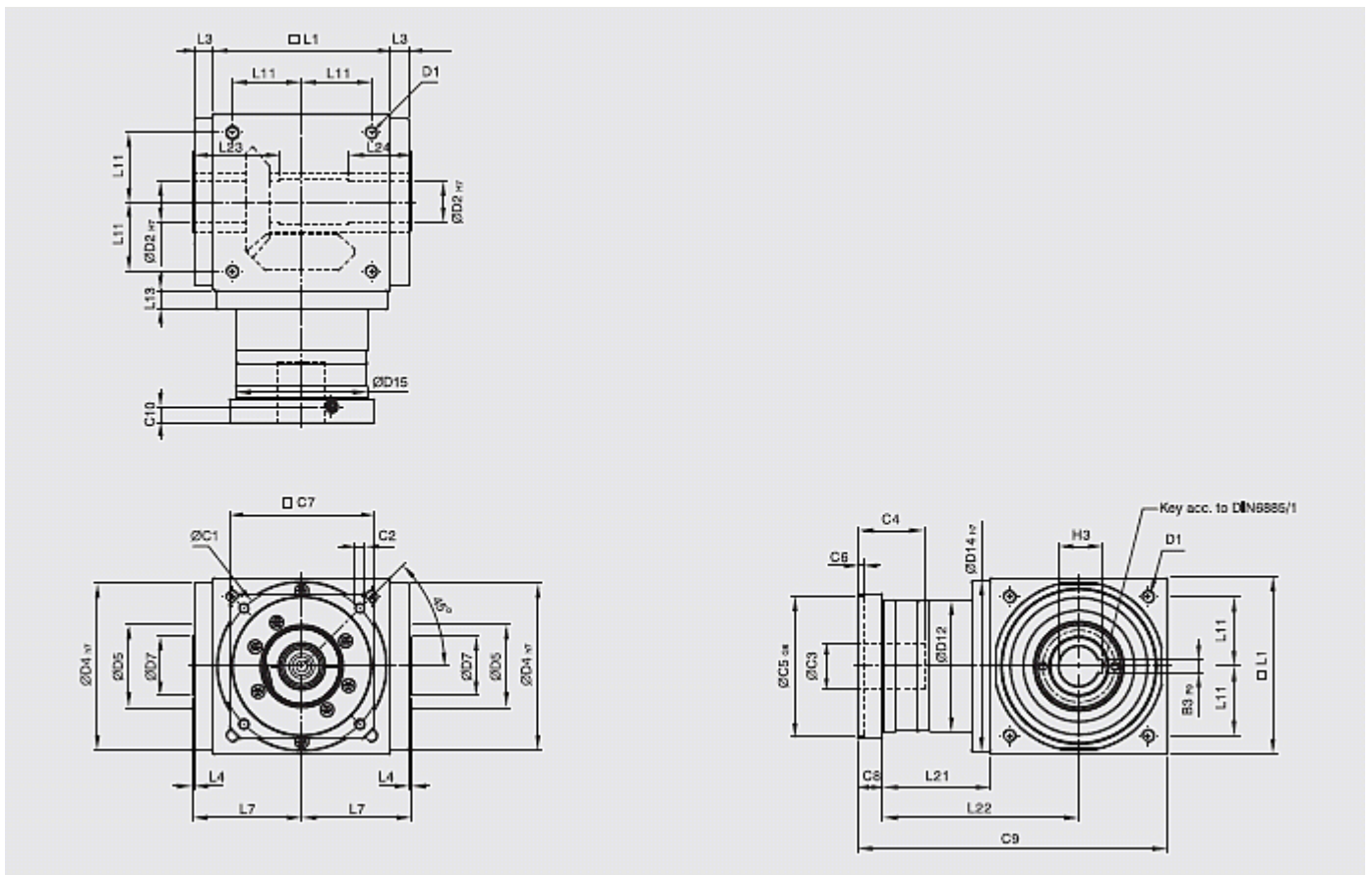

	ATB110FH	ATB140FH	ATB170FH	ATB210FH	ATB240FH	ATB280FH
D1	M8	M10	M12	M16	M16	M16
D2 _{H7}	22	32	40	50	55	60
D4 _{H7}	108	135	165	205	235	275
D5	53	68	83	104	124	144
D7	33	47	55	75	85	110
D12	106	104	128	160	180	200
D14 _{H7}	108	135	165	205	235	275

D15	107	106	127	158	178	198
L1	110	140	170	210	240	280
L3	15	15	15	20	25	25
L4	2	2	2	2	2	2
L7	72	87	102	127	147	167
L11	44	55	67	85	95	110
L13	15	15	15	20	25	25
L21	136.5	159.5	183.5	226	269	278
L22	191.5	229.5	268.5	331	389	418
L23	60	70	80	95	115	130
L24	40	50	55	65	80	80
C1 ¹¹	46	46	70	70	100	100
C2 ¹¹	M4	M4	M5	M5	M6	M6
C3 ¹¹	≤12	≤12	≤16	≤16	≤24	≤24
C4 ¹¹	30	30	34	34	40	40
C5 ¹¹ _{G6}	30	30	50	50	80	80
C6 ¹¹	3.5	3.5	8	8	4	4
C7 ¹¹	42	42	60	60	92	92
C8 ¹¹	21.5	21.5	21.5	21.5	20	20
C9 ¹¹	268	321	375	457.5	529	578
C10 ¹¹	14.5	14.5	15.5	15.5	13	13
B3 _{p9}	6	10	12	14	16	18
H3	24.8	35.3	43.3	53.8	59.3	64.4

11. C1~C10 are motor specific dimensions (metric std shown).