

KF-S2 series

Overview

- Black coated steel housing, aluminum output and motor adapter flange
- Steel output shaft, with key
- Hypoid gear design
- Nominal torques:
 - T_{2N} : 18 Nm – 1.600 Nm
- Ratios
 - 1-stage : 3 / 4 / 5 / 7 / 10
- Low backlash
 - 1-stage : ≤ 3 arcmin
- High efficiency
 - 1-stage : $\geq 96\%$
- Easy mount
- High accuracy
- The output shaft rotates in the same direction as the servomotor
- Available sizes: KH 064 / KH 090 / KH 110 / KH 140 / KH 200 / KH 255 / KH 285



Specifications

| KF | Stage | Ratio ⁽¹⁾ | KF | KF | KF | KF | KF | KF | KF | KF |
|---|------------|----------------------|-------|--------------------------------------|-------|-------|--------|--------|--------|--------|
| | | | 064 | 090 | 110 | 140 | 200 | 255 | 285 | |
| Nominal output torque T_{2N} | Nm | 1 | 3 | 25 | 50 | 110 | 210 | 420 | 820 | 1.600 |
| | | | 4 | 25 | 60 | 110 | 210 | 420 | 820 | 1.600 |
| | | | 5 | 25 | 60 | 110 | 210 | 420 | 820 | 1.600 |
| | | | 7 | 23 | 50 | 100 | 200 | 390 | 750 | 1.400 |
| | | | 10 | 18 | 40 | 85 | 170 | 360 | 600 | 1.100 |
| Emergency stop torque T_{2NOT} | Nm | 1 | 3~10 | 2 times of nominal torque T_{2N} | | | | | | |
| Max. Acceleration torque T_{2B} | Nm | 1 | 3~10 | 1,5 times of nominal torque T_{2N} | | | | | | |
| No load running torque ⁽⁴⁾ | Nm | 1 | 3~10 | 0,9 | 1,6 | 3,2 | 4,2 | 9,6 | 16,5 | 26,4 |
| Backlash ⁽²⁾ | arcminutes | 1 | 3~10 | ≤ 3 | ≤ 3 | ≤ 3 | ≤ 3 | ≤ 3 | ≤ 3 | ≤ 3 |
| Torsional rigidity | Nm/arcmin | 1 | 3~10 | 1,1 | 4,5 | 10 | 23 | 54 | 90 | 170 |
| Nominal input speed n_{1N} | rpm | 1 | 3~10 | 3.000 | 2.800 | 2.700 | 2.000 | 2.000 | 2.000 | 1.500 |
| Max. input speed n_{1B} | rpm | 1 | 3~10 | 6.000 | 6.000 | 4.500 | 4.500 | 4.000 | 3.000 | 2.500 |
| Max. radial load F_{2rB} ⁽³⁾ | N | 1 | 3~10 | 2.400 | 4.500 | 5.100 | 13.000 | 28.700 | 36.200 | 58.300 |
| Max. axial load F_{2aB} ⁽³⁾ | N | 1 | 3~10 | 1.200 | 2.250 | 2.550 | 6.500 | 14.350 | 18.100 | 29.150 |
| Service Life ⁽⁵⁾ | hr | 1 | 3~100 | 20.000 | | | | | | |
| Operating temperature | °C | 1 | 3~100 | 0° C ~ +90° C | | | | | | |
| Degree of Protection | | 1 | 3~100 | IP65 | | | | | | |
| Lubrication | | 1 | 3~100 | Synthetisch lubrication grease | | | | | | |
| Mounting position | | 1 | 3~100 | All directions | | | | | | |
| Running noise ⁽⁴⁾ | dB (A) | 1 | 3~100 | ≤ 64 | ≤ 66 | ≤ 66 | ≤ 68 | ≤ 68 | ≤ 70 | ≤ 72 |
| Efficiency η | % | 1 | 3~10 | ≥ 96% | | | | | | |

(1) Ratio ($i = N_{in} / N_{out}$)

(2) Backlash is measured at 2% of Nominal output torque T_{2N} .

(3) Applied to the output shaft center @ 100 rpm .

(4) These values are measured by gearbox with ratio = 10 (1-stage) or ratio = 100 (2-stage) at 3.000 rpm without load.

(5) For continuous operation, the service life is less than 10.000 hrs.

Permitted Radial And Axial Loads

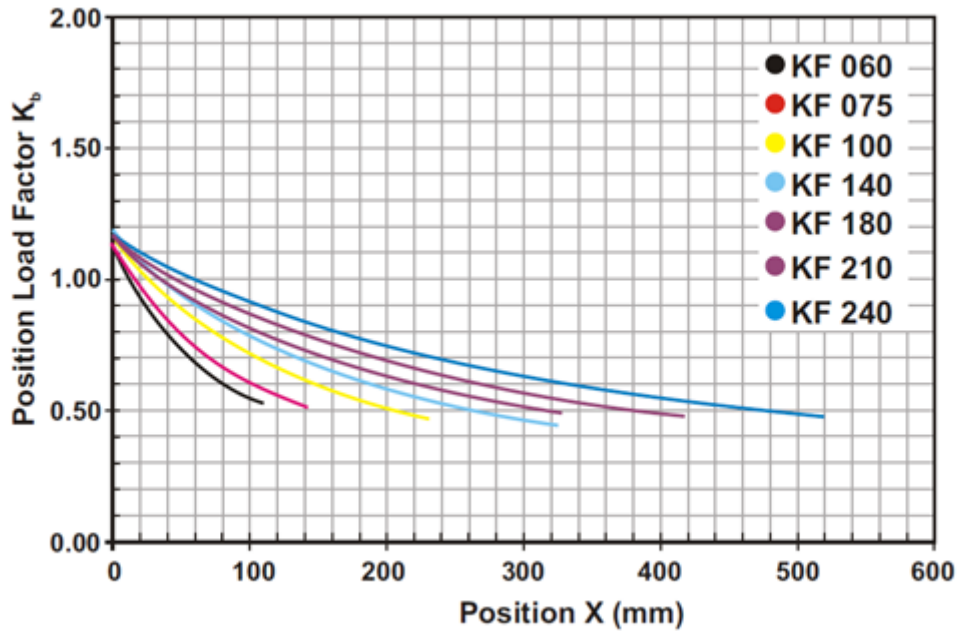

If radial force F_{2r} is not exerted on the center of the output shaft $X < \frac{1}{2} \times L$ or $X > \frac{1}{2} \times L$, the permitted radial and axial loads can be calculated by the position load factor K_b on the above diagram.

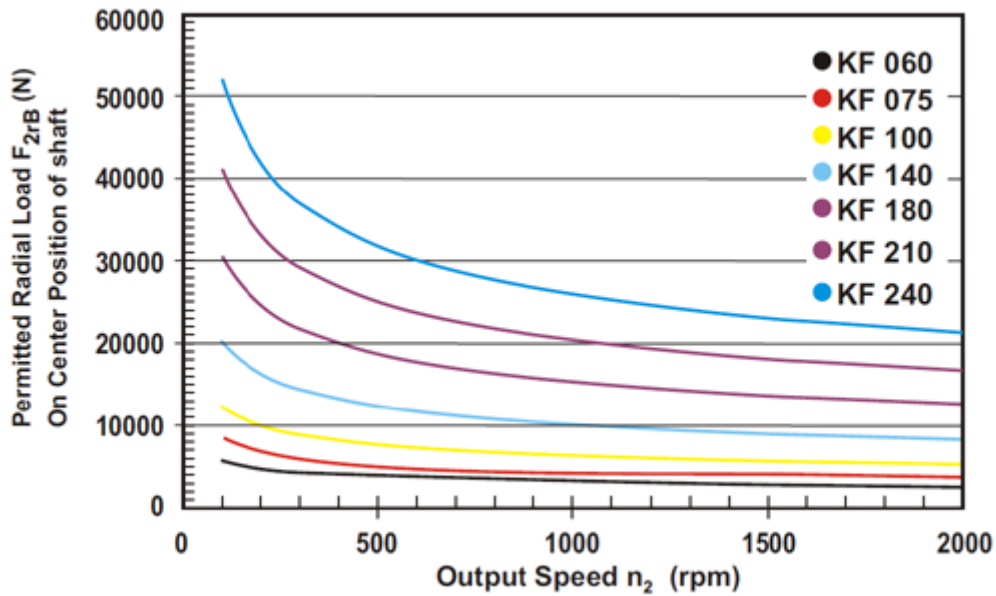

Permitted radial load F_{2r} on center of output shaft $X = \frac{1}{2} \times L$ for various output speeds. Values provided are for 20,000 hours life.

(A) \emptyset Input shaft diameter

(B) Permitted loading values on the output shaft. Please contact Apex Dynamics for more details.

(C) For continue mode (S1), the service life is reduced to 50%.

Inertia

| Model No. | KF 064 | KF 090 | KF 110 | KF 140 | KF 200 | KF 255 | KF 285 |
|------------------------|--------------------|---------|---------|---------|---------|---------|---------|
| $\emptyset^{(A)}$ (C3) | 1-stage | 1-stage | 1-stage | 1-stage | 1-stage | 1-stage | 1-stage |
| 8 | 0,10 | - | - | - | - | - | - |
| 11 | 0,17 | 0,18 | - | - | - | - | - |
| 14 | 0,20 | 0,50 | - | - | - | - | - |
| 19 | - | 0,63 | 1,66 | - | - | - | - |
| 24 | - | 4,42 | 4,82 | 4,96 | - | - | - |
| 28 | - | - | 6,05 | 6,00 | - | - | - |
| 32 | - | - | 8,38 | 8,70 | 9,93 | - | - |
| 35 | - | - | 13,86 | 14,23 | 15,15 | 15,62 | 23,34 |
| 38 | kg*cm ² | - | 18,87 | 19,88 | 20,69 | 21,61 | 23,34 |
| 42 | - | - | - | 21,75 | 22,26 | 23,36 | 24,97 |
| 48 | - | - | - | 53,91 | 55,55 | 58,28 | 60,43 |
| 55 | - | - | - | - | - | 86,65 | 88,67 |
| 60 | - | - | - | - | - | - | 111,89 |

(A) \emptyset Input shaft diameter

Sizes

KF-S1 / S2 / S3:

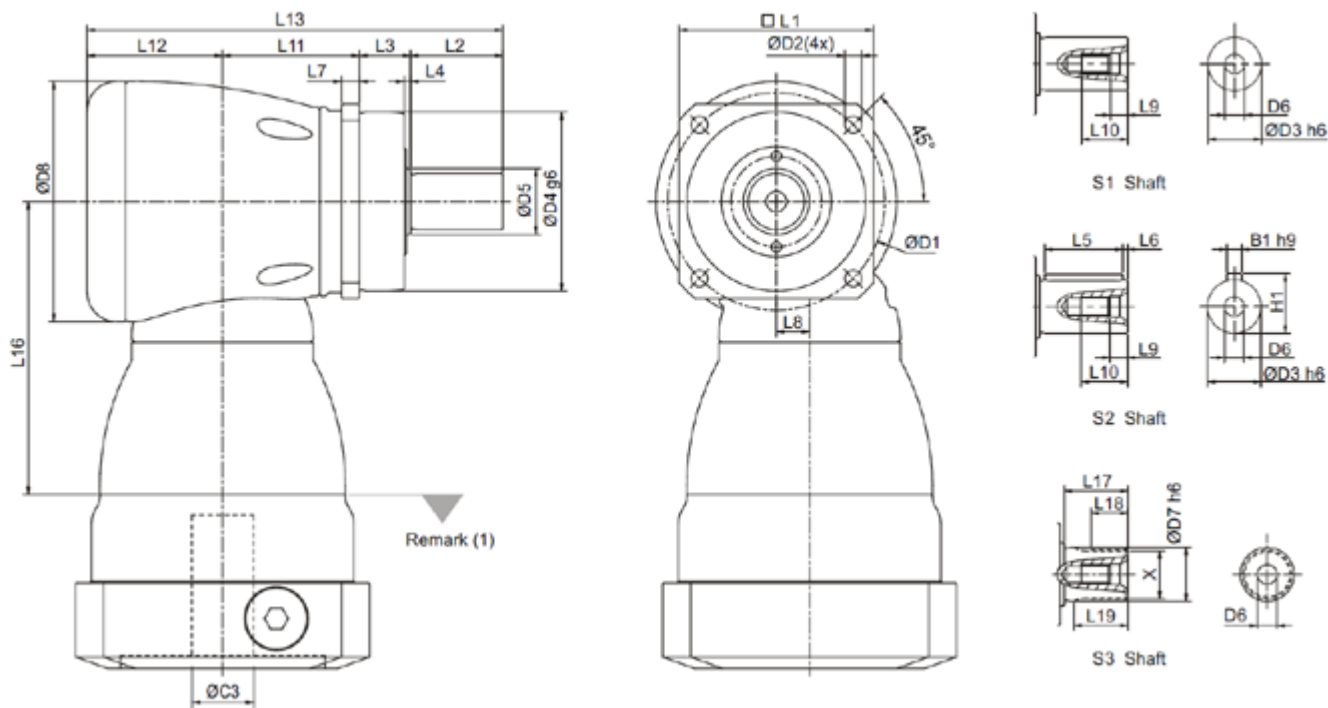

| Dimension | KF 060 | KF 075 | KF 100 | KF 140 | KF 180 | KF 210 | KF 240 |
|-----------|---------|----------|-----------|---------|----------|----------|----------|
| | 1-stage | 1-stage | 1-stage | 1-stage | 1-stage | 1-stage | 1-stage |
| D1 | 68 | 85 | 120 | 165 | 215 | 250 | 290 |
| D2 | 5,5 | 6,6 | 9 | 11 | 13,5 | 17 | 17 |
| D3 h6 | 16 | 22 | 32 | 40 | 55 | 75 | 85 |
| D4 g6 | 60 | 70 | 90 | 130 | 160 | 180 | 200 |
| D5 | 18,5 | 25,8 | 36,8 | 55,2 | 69,2 | 82,2 | 92,2 |
| D6 | M5x0,8P | M8x1,25P | M12x1,75P | M16x2P | M20x2,5P | M20x2,5P | M20x2,5P |
| D7 h6 | 16 | 22 | 32 | 40 | 55 | 75 | 85 |
| D8 | 73 | 94 | 116 | 163 | 210 | 255 | 300 |
| L1 | 62 | 76 | 101 | 141 | 182 | 215 | 245 |
| L2 | 28 | 36 | 58 | 82 | 82 | 105 | 130 |
| L3 | 20 | 20 | 30 | 30 | 30 | 38 | 40 |
| L4 | 2 | 2,5 | 3 | 3 | 3 | 3 | 3 |
| L5 | 25 | 32 | 50 | 63 | 70 | 90 | 125 |
| L6 | 2 | 2 | 4 | 5 | 6 | 7 | 3 |
| L7 | 6 | 7 | 10 | 12 | 15 | 17 | 20 |
| L8 | 10 | 13 | 17 | 25 | 31 | 36 | 43 |
| L9 | 4,8 | 7,2 | 10 | 12 | 15 | 15 | 15 |
| L10 | 12,5 | 19 | 28 | 36 | 42 | 42 | 42 |
| L11 | 43 | 53,5 | 67 | 90 | 119 | 141 | 176 |
| L12 | 44,5 | 53 | 68,3 | 89 | 115 | 131 | 165 |
| L13 | 135,5 | 162,5 | 223,3 | 291 | 346 | 415 | 511 |
| L16 | 94 | 114,5 | 129 | 173,5 | 228 | 265,5 | 294,5 |
| L17 | 26 | 26 | 26 | 40 | 41,5 | 52 | 60 |
| L18 | 15 | 15 | 15 | 20 | 21,5 | 28 | 36 |
| L19 | 21 | 22,5 | 23 | 33,5 | 33,5 | 45 | 53 |
| B1 h9 | 5 | 6 | 10 | 12 | 16 | 20 | 22 |
| H1 | 18 | 24,5 | 35 | 43 | 59 | 79,5 | 90 |

(1) Dimensions are related to motor interface. Please contact Apex Dynamics for details.