

PAII series

Overview

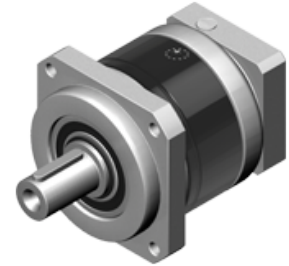

- Black coated steel housing, aluminum output and motor adapter flange
- Steel output shaft with key
- Spur gear design
- Nominal torques:
 - T_{2N} : 8 Nm – 459 Nm
- Ratios
 - 1-stage : 3 / 4 / 5 / 7 / 9 / 10
 - 2-stage : 15 / 16 / 20 / 25 / 30 / 35 / 40 / 50 / 70 / 81 / 100
- Low backlash
 - 1-stage : $\leq 6 \sim 8$ arcmin
 - 2-stage : $\leq 8 \sim 10$ arcmin
- High efficiency
 - 1-stage : $\geq 97\%$
 - 2-stage : $\geq 94\%$
- Easy mount
- Compact structure
- Sizes available: PAII 042 / PAII 060 / PAII 090 / PAII 115 / PAII 142

Specifications

PAII		Stage	Ratio ⁽¹⁾	Type	PAII 042	PAII 060	PAII 090	PAII 115	PAII 142
Nominal output torque T_{2N}	Nm	All	3		16	42	110	217	430
			4		16	42	113	223	440
			5		15	40	118	220	435
			7		12	35	96	198	366
			9		8	24	60	125	273
			10		10	27	68	155	295
			15		15	40	109	213	424
			16		16	42	116	228	452
			20		16	42	116	230	454
			25		15	40	123	228	450
			30		15	40	108	212	422
			35		12	35	100	206	382
			40		16	43	117	232	459
			50		15	40	123	228	450
			70		12	35	100	206	382
81		8	24	59	131	285			
100		10	27	70	162	308			
Emergency stop torque T_{2NOT}	Nm	1,2	3~100	All	3 times nominal output torque T_{2N}				
Max. Acceleration torque T_{2B}	Nm	1,2	3~100	All	$T_{2B} = 60\%$ of T_{2NOT}				
No load running torque ⁽⁴⁾	Nm	1	3~10	All	0,05	0,1	0,4	0,8	2,5
		2	15~100	All	0,05	0,1	0,3	0,4	0,8
Backlash ⁽²⁾	arcmin	1	3~10	All	≤ 8	≤ 7	≤ 6	≤ 6	≤ 6
		2	15~100	All	≤ 10	≤ 9	≤ 8	≤ 8	≤ 8
Torsional rigidity ⁽⁴⁾	Nm/arcmin	1,2	3~100	PAII	0,9	2,2	8	12	16
Nominal input speed n_{1N}	rpm	1,2	3~100	All	4.500	4.000	3.600	3.600	2.500
Max. input speed n_{1B}	rpm	1,2	3~100	All	8.000	6.000	6.000	4.800	3.600
Max. radial load F_{2rB} ⁽³⁾	N	1,2	3~100	PSII	810	1.150	1.530	3.470	4.640
Max. axial load F_{2aB} ⁽³⁾	N	1,2	3~100	PAII	405	575	765	1.735	2.320
Service Life ⁽⁵⁾	hr	1,2	3~100	All	20.000				
Operating temperature	°C	1,2	3~100	All	0° C ~ +90°C				
Degree of Protection		1,2	3~100	All	IP65				
Lubrication		1,2	3~100	All	Synthetisch lubrication grease				
Mounting position		1,2	3~100	All	All directions				
Running noise ⁽⁴⁾	dB (A)	1,2	3~100	All	≤ 60	≤ 62	≤ 64	≤ 66	≤ 68
Efficiency η	%	1	3~10	All	≥ 97%				
		2	15~100	All	≥ 94%				

(1) Ratio ($i = N_{in} / N_{out}$).

(2) Backlash is measured at 2% of Nominal output torque T_{2N} .

(3) Applied to the output shaft center @ 100 rpm .

(4) These values are measured by gearbox with ratio = 10 (1-stage) or ratio = 100 (2-stage) at 3.000 rpm without load.

(5) For continuous operation, the service life is less than 10.000 hrs.

Permitted Radial And Axial Loads

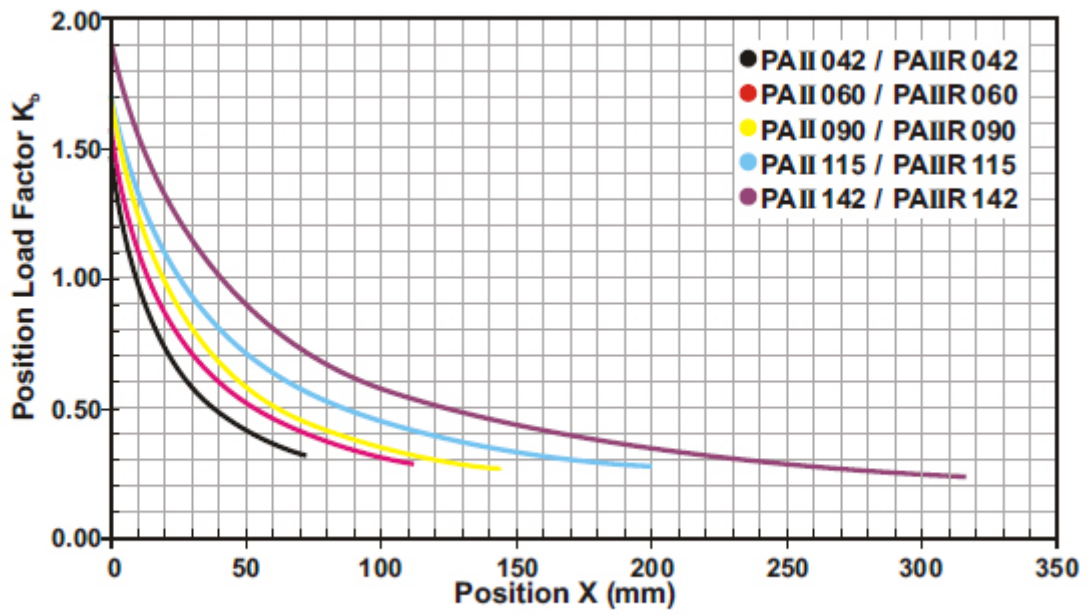
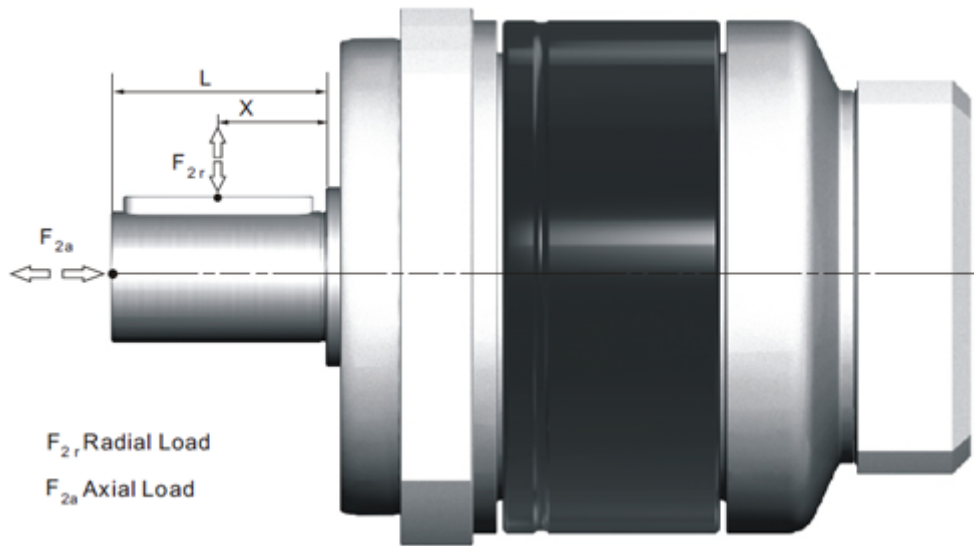

If radial force F_{2r} is not exerted on the center of the output shaft $X < \frac{1}{2} \times L$ or $X > \frac{1}{2} \times L$, the permitted radial and axial loads can be calculated by the position load factor K_b on the above diagram.

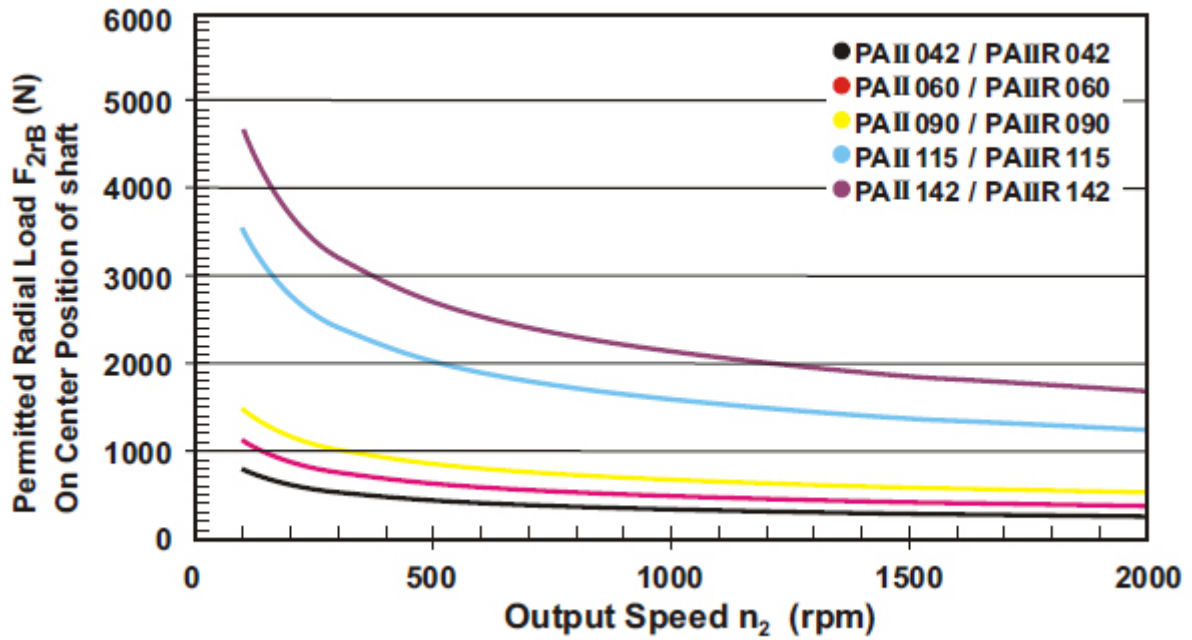

Permitted radial load F_{2r} on center of output shaft $X = \frac{1}{2} \times L$ for various output speeds. Values provided are for 20.000 hours life.

(A) \emptyset Input shaft diameter

(B) Permitted loading values on the output shaft. Please contact Apex Dynamics for more details.

(C) For continue mode (S1), the service life is reduced to 50%.

Inertia

Model No. $\emptyset^{(A)}$ (C3)	PAII 042		PAII 060		PAII 090		PAII 155		PAII 142	
	1-traps	2-traps	1-traps	2-traps	1-traps	2-traps	1-traps	2-traps	1-traps	2-traps
8	0,10	0,10	0,12	0,10	-	-	-	-	-	-
11	0,16	0,16	0,19	0,16	-	-	-	-	-	-
14	-	-	-	0,20	0,36	0,24	-	-	-	-
19	-	-	1,53	1,51	1,70	1,58	2,20	1,73	-	2,18
24	-	-	-	-	2,24	2,12	2,74	2,27	4,52	2,73
28	-	-	-	-	2,68	2,55	3,17	2,70	4,94	3,15
32	-	-	-	-	-	-	7,77	7,30	9,70	7,91
35	-	-	-	-	-	-	10,80	10,30	12,80	11,00
38	-	-	-	-	-	-	14,00	13,50	16,00	14,20
42	-	-	-	-	-	-	-	-	24,50	-

(A) \emptyset = Input shaft diameter

Sizes

PAII serie:

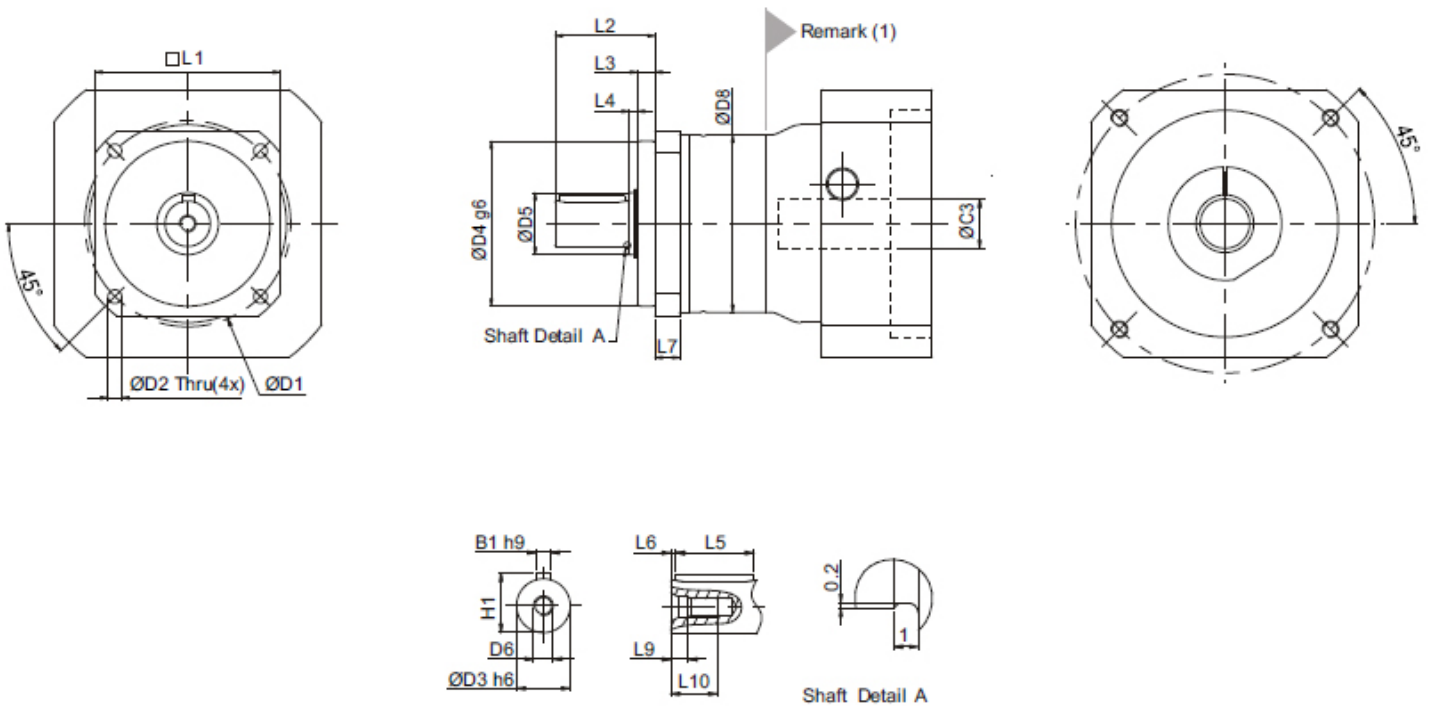

Afmeting	PAII 042		PAII 060		PAII 090		PAII 115		PAII 142	
	1-traps	2-traps	1-traps	2-traps	1-traps	2-traps	1-traps	2-traps	1-traps	2-traps
D1	50		70		100		130		165	
D2	3,4		5,5		6,6		9		11	
D3 h7	13		16		22		32		40	
D4 g7	35		50		80		110		130	
D5	17		22		30		40		55	
D6	M4 x 0,7P		M5 x 0,8P		M8 x 1,25P		M12 x 1,75P		M16 x 2P	
D8	44		60		86		114		140	
L1	42		60		90		115		142	
L2	26		37		48,5		65		97	
L3	5,5		5,5		8,5		10		12,5	
L4	2,5		3,5		4		5		5,5	
L5	14		25		32		40		63	
L6	2		2		2		5		5	
L7	6,5		10		12		16		20	
L9	4,5		4,8		7,2		10		12	
L10	10		12,5		19		28		36	
B1 h9	5		5		6		10		12	
H1	15		18		24,5		35		43	

(1) Dimensions are related to motor interface. Please contact Apex Dynamics for details.