

AFHK series (2 stage)

Overview

- High torque right-angle hypoid gearbox
- Special design for continuous (S1) or cyclic (S5) duty operation
- Steel housing/aluminum, aluminum black anodized motor adapter flange
- Steel output shaft with or without key, with spline (DIN5480) or hollow shaft
- Helical gear design
- Nominal torques:
 - T_{2N} : 24 Nm – 3.340 Nm
- Ratios
 - 2-stage : 12 / 16 / 20 / 25 / 28 / 35 / 40 / 50 / 70 / 100
- Low backlash
 - 2-stage : ≤ 2 arcmin / ≤ 3 arcmin
- High efficiency
 - 2-stage : $\geq 94\%$
- Easy mount
- Low noise
- Compact structure
- Sizes available: AFHK060 / AFHK075 / AFHK100 / AFHK140 / AFHK180 / AFHK210 / AFHK240



Specifications

Model No.	Stage	Ratio ¹	AFHK060	AHK075	AFHK100	AFHK140	AFHK180	AFHK210	AFHK240	
Nominal Output Torque T_{2N}	Nm	2	12	95	195	360	615	1,315	1,680	3,280
			16	95	200	360	615	1,320	1,680	3,280
			20	95	200	360	615	1,320	1,775	3,335
			25	80	170	310	535	1,165	1,775	3,335
			28	92	200	360	615	1,325	1,560	3,000
			35	80	170	310	535	1,170	1,775	3,000
			40	60	160	340	615	1,325	1,440	2,400
			50	50	170	310	535	1,170	1,775	3,000
			70	60	130	250	440	990	1,510	2,550
			100	24	55	160	290	655	1,005	1,685
Emergency Stop Torque T_{2Not}	Nm	2	12~100			2 times T_{2N}				
Max. Acceleration Torque T_{2b}	Nm	2	12~100			1.5 times T_{2N}				
No Load Running Torque ⁽²⁾	NM	2	12~100	1	1.3	2	3.1	6	13	16
Backlash ⁽³⁾	arcmin	2	12~100	≤3	≤2	≤2	≤2	≤2	≤2	≤2
Torsional Rigidity	Nm/arcmin	2	12~100	4.6	10	30	55	175	300	510
Nominal Input Speed n_{1N}	rpm	2	12~100	3,000	3,000	2,800	2,700	2,200	2,100	2,000
Max. Input Speed	rpm	2	12~100	6,000	6,000	6,000	4,500	4,500	4,000	3,000
Max. Radial Load $F_{2r}^{(4)}$	N	2	12~100	3,000	4,500	6,700	10,000	15,000	22,000	30,000
Max. Axial Load $F_{2a}^{(4)}$	N	2	12~100	1,500	2,250	3,350	5,000	7,500	11,000	15,000
Max. Tilting Moment $M_{2k}^{(4)}$	Nm	2	12~100	160	270	550	1,050	1,740	3,350	5,420
Service Life ⁽⁵⁾	hr	2	12~100	20,000						
Operating Temp.	°C	2	12~100	-10° C ~ 90° C						
Degree of Gearbox Protection		2	12~100	IP65						
Lubrication		2	12~100	Synthetic lubrication grease						
Mounting Position		2	12~100	All directions						
Running Noise ⁽⁶⁾	dB(A)	2	12~100	≤64	≤66	≤68	≤68	≤70	≤70	≤72
Efficiency	%	2	12~100	≥94%						

(1) Ratio ($i = N_{in} / N_{out}$)

(2) These values are measured by gearbox with ratio 100 (2-stage) at 3,000 rpm no loading.

- (3) Backlash is measured at 2% of Nominal Output Torque T_{2N}
- (4) Applied to the output shaft center at 100 rpm.
- (5) Continuous operation is not recommended.
- (6) These values are measured by gearbox with ratio 10 (1-stage) or ratio 100 (2-stage) at 3,000 rpm no loading. By lower ratio and/or higher RPM, the noise level could be 3 to 5 dB higher.

Inertia

Model No.	AFHK060	AFHK075	AFHK100	AFHK140	AFHK180	AFHK210	AFHK240
$\emptyset^{(A)}$ C3	2-st	2-st	2-st	2-st	2-st	2-st	2-st
8	0.10	-	-	-	-	-	-
11	0.16	0.17	-	-	-	-	-
14	0.20	0.37	0.41	-	-	-	-
19	-	0.60	1.61	1.61	-	-	-
24	-	-	3.90	4.01	5.62	-	-
28	-	-	-	5.53	5.62	-	-
32	-	-	-	7.57	8.11	8.11	-
35	-	-	-	14.95	15.32	15.32	15.68
38	-	-	-	17.58	17.72	17.72	18.52
42	-	-	-	-	22.95	22.95	23.74
48	-	-	-	-	52.74	52.74	53.49
55	-	-	-	-	-	-	87.34

(A) \emptyset = Input shaft diameter.

Sizes

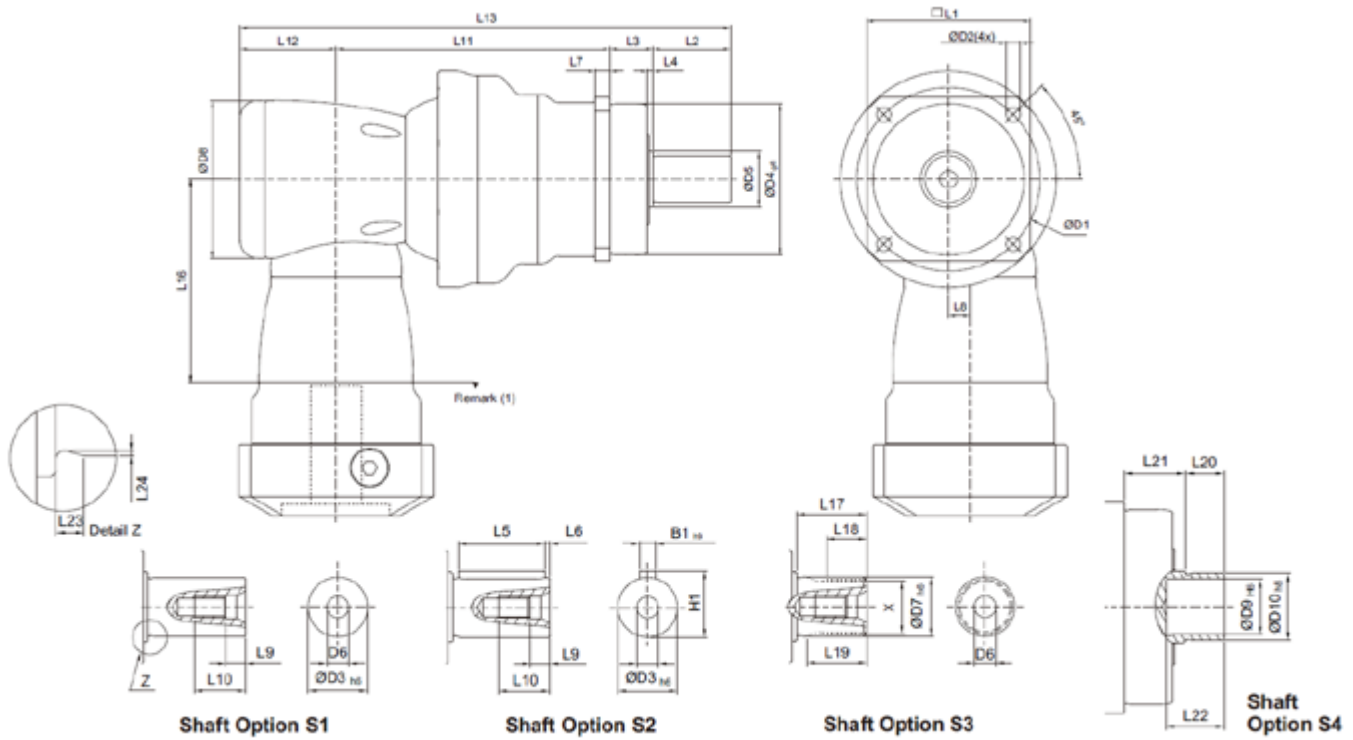

	AFHK060	AFHK075	AFHK100	AFHK140	AFHK180	AFHK210	AFHK240
D1	68	85	120	165	215	250	290
D2	5.5	7	9	11	13.5	17	17
D3 h6	16	22	32	40	55	75	85
D4 g6	60	70	90	130	160	180	200
D5	18.5	25.8	36.8	55.2	69.2	82.2	92.2
D6	M5 x 0.8P	M8 x 1.25P	M12 x 1.75P	M16 x 2P	M20 x 2.5P	M20 x 2.5P	M20 x 2.5P
D7 h6	16	22	32	40	55	75	85
D9 H6	15	20	30	40	55	-	-
D10 h8	18	24	36	50	68	-	-
L1	62	76	101	141	182	215	245
L2	28	36	58	82	82	105	130
L3	20	20	30	30	30	38	40
L4	2	2.5	3	3	3	3	3
L5	25	32	50	63	70	90	125
L6	2	2	4	5	6	7	3
L7	6	7	10	12	15	17	22
L9	4.8	7.2	10	12	15	15	15
L10	12.5	19	28	36	42	42	42
L17	26	26	26	40	41.5	52	60
L18	15	15	15	20	21.5	28	36
L19	21	22.5	23	33.5	33.5	45	53
L20	12	14	18	22	23	-	-
L21	22	22	32	33	32	-	-
L22	19	21	25	30	30	-	-
L23	2	2.5	2.5	2.5	2.5	2.5	4
L24	0.3	0.4	0.4	0.4	0.4	0.4	0.5
B1 h9	5	6	10	12	16	20	22
H1	18	24.5	35	43	59	79.5	90
X DIN5480	W16x0.8x30x18x6m	W22x1.25x30x16x6m	W32x1.25x30x24x6	W40x2x30x18x6m	W55x2x30x26x6m	W70x2x30x34x6m	W80x2x30x38x6m

(1) Dimensions are related to motor interface. Please contact APEX for details.